

Feb. 1998



MOTORHOME OWNER'S MANUAL



Gulf Stream Coach, Inc.

Nappanee, Indiana



**GULF STREAMERS
INTERNATIONAL RV CLUB
APPLICATION-PAGE 29**

GULF STREAM COACH OPERATOR'S MANUAL

Congratulations!

You are the proud owner of a new GULF STREAM COACH motorhome, a remarkable recreational vehicle that has been engineered, tested and built to meet your traveling and relaxation needs for many pleasurable years to come.

Many thousands of individuals have preceded you onto the highways of America, Canada and Mexico in GULF STREAM recreational vehicles, enjoying the beauty of nature and the companionship of good people. Through personal contacts, both on the road and over the phone, GULF STREAM's engineering and manufacturing staff has learned a lot about how our customers utilize their vehicles. We've put thousands of miles on our own test vehicles over the same roads many of our customers travel each year.

It's been our experience that if a customer plans well, follows the basic rules of the road and the design limitations placed on their vehicle and its equipment, that they will enjoy thousands of care-free miles.

That's why we've included this operator's manual in your Owner's Packet along with the individual instruction booklets for all your appliances, optional equipment and a detailed Operator's Manual from the manufacturer of your chassis and motor. The more information you have available to you, the more you will get out of your new vehicle.

Please read over this manual and all the other owner's manuals included in your packet. It will make your initial trips in your new GULF STREAM much more pleasurable and save time in the long haul.

Good traveling and good camping!

Sincerely,

Gulf Stream Coach, Inc.
P.O. Box 1005
Nappanee, Indiana 46550

TABLE OF CONTENTS

Table of Contents	1	LP Gas	15
Warranty	3	General	15
LP Gas Safety Statement	3	Climate Differences	16
Approaching the Open Road		Operation	16
in a Professional Manner	4	Filling the LP Tank	16
Preparing for the Road	4	Gas Line Check	16
General Safety Tips	4	Regulator Pressure	16
Seat Belt Usage	4	Gas Tank Regulator Freeze-Up	17
Seat Belt Maintenance	4	Hose Replacement	17
Fire Safety	4	Regulator Vent Maintenance	17
Smoke Detector	5	Plumbing	17
LP Gas Safety	5	Fresh Water	17
Gasoline Tank Safety	5	Sanitizing the Water Tank	17
Vehicle Loading	5	Water Pump	18
Vehicle Carrying Capacity	5	Winterizing the Water Pump	18
Loading Tips	6	Troubleshooting Water Pump Problems	18
Manufacturer's Labels	6	Leaks	18
Federal Weight Definitions	6	Drainage and Sewer	18
Determining Weight and Weight Distribution	7	Holding Tanks	19
The Method of Weighing Your Vehicle	7	Emptying Holding Tanks	19
Vehicle Weight Planning Guide	7	Drain Piping	19
Air Bag Warning	8	Water Heater	20
Dangers of Overloading	8	Water System Winterizing	20
Vehicle Towing	8	Appliances	20
Emergency Towing of the Motor Home	8	Water Heater	21
Pre-Trip Checklist – Home	9	Range	21
Pre-Trip Checklist – Campsite	9	Microwave	21
Day-to-Day Operation	10	Refrigerator	21
Driving	10	Dishwasher	21
Driver Controls	10	Washer/Dryer	21
Tilt Steering Wheel	10	Furnishings	21
Cruise Control	10	Tables	21
Seat Adjustment	10	Beds	21
Brakes	10	Chairs	22
Dashboard Instruments	11	Cabinets	22
Two-Speed Cooling Fan Noise	11	Walls	22
Unused Dashboard Switches	12	Carpets	22
Starting and Vehicle Warm-Up	12	Climate Control	22
Important Operating Instructions for		Furnace	23
Turbo Charged Diesel Engine	12	Air Conditioner	23
Jump Starting	12	Effects of Long Term Occupancy	23
Jump Starting Tip	12	Controlling Condensation	23
Safety	13	Dehumidifier	23
Emergency Exits	13	Vehicle Maintenance	23
Fire Extinguisher	13	Reporting Safety Defects	24
Smoke Detector	13	Ready Reference	24
Safety Belts	13	Index	27
Warning Hazard Flashers	13	Gulf Streamers	29
Emergency/Parking Brake	13		
Electrical	13		
12-Volt 110-Volt	13		
Power Converter	13		
Ground Fault Interrupter	14		
Automotive 12-Volt System	14		
Battery	14		
On-Board Auxiliary Power Generator (Optional)	15		
Fuse Boxes	15		
Monitor Panel	15		
Television Electrical Connection	15		

GULF STREAM WARRANTY AND WARRANTY SERVICE

GULF STREAM WARRANTY

Please review the Gulf Stream twelve-month or 12,000 mile limited warranty supplied with your vehicle.

WARRANTY SERVICE

1. Warranty service, under your 12-month or 12,000 mile limited warranty, is to be performed by your authorized Gulf Stream dealer from whom you purchased your unit or by an authorized service center for those appliances and equipment not maintained by Gulf Stream. Your dealer has a vested interest in your satisfaction, therefore, if at all possible, it is best to return to your dealer for service.
2. If you are traveling or move, service may be provided by any authorized dealer. Keep your warranty registration form with the vehicle at all times since it must be presented for warranty service. This form is your proof of purchase and provides the date of retail sale, both of which are necessary to determine warranty eligibility.
3. If you cannot locate an authorized Gulf Stream dealer or you require emergency service, contact:
Gulf Stream Coach, Inc.
P.O. Box 1005
Nappanee, IN 46550
1-800-289-8787 For Class A Motorhomes
1-800-284-3151 For Class C Motorhomes
4. Other warranties - The Retail customer is responsible for completing and forwarding warranty forms for all items not covered by either the chassis manufacturer's or Gulf Stream's warranty.

Your authorized Gulf Stream Dealer from whom you purchased your unit will assist you in service, maintenance, selection of options, and instructions concerning the operation of your recreational vehicle. Occasionally, a warranty or service matter may not be handled to your satisfaction. In this case, we recommend that you discuss the problem with dealer management. If you are unable to find satisfaction at the dealer level, please contact the Gulf Stream Service Department where we will make our best effort to reach an agreeable solution. In

most instances, we will eventually refer you back to the local dealer with our recommendations.

Contact the Gulf Stream Service Department at:
Gulf Stream Coach, Inc.
P.O. Box 1005
Nappanee, IN 46550

LP GAS HEATING SYSTEM AND LP GAS APPLIANCE SAFETY REGULATIONS

The United States Government requires that the manufacturer of this recreational vehicle provide the following safety information that has been provided by the National Fire Prevention Association and the American National Standards Institute. The information contained below will also be found, along with additional information, in other appropriate sections of the operator's manual. Refer to the Table of Contents and the Index.

WARNING: LP GAS CONTAINERS SHALL NOT BE PLACED OR STORED INSIDE THE VEHICLE. LP GAS CONTAINERS ARE EQUIPPED WITH SAFETY DEVICES THAT RELIEVE EXCESSIVE PRESSURE BY DISCHARGING GAS TO THE ATMOSPHERE.

WARNING: IT IS EXTREMELY DANGEROUS TO USE COOKING APPLIANCES FOR COMFORT HEATING. COOKING APPLIANCES NEED FRESH AIR FOR SAFE OPERATION. BEFORE OPERATION (1) OPEN THE OVERHEAD VENT OR TURN ON AN EXHAUST FAN AND (2) OPEN A NEARBY WINDOW. A WARNING LABEL HAS BEEN PLACED IN THE COOKING AREA OF THE VEHICLE TO REMIND YOU THAT YOU MUST PROVIDE AN ADEQUATE SUPPLY OF FRESH AIR FOR COMBUSTION. UNLIKE HOMES, THE AMOUNT OF AIR IN AN RV IS LESS DUE TO ITS LIMITED SIZE (VOLUME). PROPER VENTILATION WHEN USING COOKING APPLIANCES WILL AVOID THE DANGERS OF ASPHYXIATION. THE THREAT OF ASPHYXIATION INCREASES WHEN A COOKING APPLIANCE IS USED FOR LONG PERIODS OF TIME. THUS, THEY SHOULD NEVER BE USED TO HEAT THE INTERIOR OF THE VEHICLE.

WARNING: PORTABLE FUEL-BURNING EQUIPMENT, INCLUDING CHARCOAL GRILLS AND STOVES, SHALL NOT BE USED INSIDE THE RECREATIONAL VEHICLE. THE USE OF THIS CATEGORY OF EQUIPMENT INSIDE AN ENCLOSED SPACE MAY CAUSE ASPHYXIATION

AND CREATES A FIRE HAZARD.

WARNING: DO NOT BRING OR STORE LP GAS CONTAINERS, GASOLINE OR OTHER FLAMMABLE LIQUIDS INSIDE THE VEHICLE DUE TO THE POSSIBILITY OF EXPLOSION AND FIRE.

A warning label has been attached near the LP gas container. The label reads: **DO NOT FILL CONTAINER(S) TO MORE THAN 80 PERCENT OF CAPACITY.**

Uncontrolled gas flow can result from the overfilling of LP gas containers, resulting in a fire or explosion. A properly filled container will contain approximately 80 percent of its volume as liquid.

The following label has been placed in the cooking area of the vehicle:

IF YOU SMELL GAS:

1. Extinguish any open flame, pilot light and smoking material.
2. Do not touch any electrical switch.
3. Shut off the LP gas supply at the tank valve(s) or gas supply connection.
4. Open doors and other ventilating openings.
5. Leave the area until odor clears.
6. Have the gas system checked and leakage source corrected before using again.

LP gas regulators must always be installed with the diaphragm vent facing down. Regulators that are not in compartments have been equipped with a protective cover. Make sure the regulator vent faces down and the cover is kept in place to minimize vent blockage; blockage could result in excessive gas pressure and, therefore, possibly cause a fire or explosion.

Notice: All LPG regulators are factory tested for proper pressure output. Pressure output should be checked periodically by a qualified LP dealer. Only qualified persons should install, adjust or service LP gas regulators. If service is needed contact a qualified LP dealer.

APPROACHING THE OPEN ROAD IN A PROFESSIONAL MANNER

As the proud owner and operator of a GULF STREAM motor home you will be commanding one of the larger privately-owned vehicles using the nation's roadways.

The only vehicles that will be as large or larger than your "rig" will be the trucks and buses of the professional driver. Don't let the car-like handling characteristics of your new GULF STREAM lull you into a less than vigilant attitude towards highway driving. Your safety, the safety of your passengers and those on the road alongside you depend on your "professional" driving attitude.

Professional drivers approach their driving responsibilities methodically from the outset of the trip. They include thorough pre-trip planning and equipment checks. They also include equipment checks along the route and take into consideration driver fatigue.

GULF STREAM COACH, Inc. provides this operator's manual so that you can approach your driving in the most

professional manner possible. Read the manual carefully. Learn your vehicle's personality. And keep this manual handy for easy reference. Before you know it, you and your machine will be a "team" and you'll be proud of the professional manner in which you approach the serious business of driving a large vehicle on the open road.

PREPARING FOR THE ROAD

GENERAL SAFETY

Seat Belt Usage

All seats designated for occupancy during travel are equipped with seatbelts for the protection and safety of passengers. Rear facing seats, as used in the dining area, are not equipped with seatbelts and should not be occupied while the vehicle is in motion.

NOTE: MANY STATES HAVE PASSED LAWS THAT REQUIRE SEATBELTS TO BE WORN BY ALL PASSENGERS WHEN THE VEHICLE IS IN MOTION.

NOTE: MANY STATES HAVE PASSED LAWS THAT REQUIRE ALL PASSENGERS UNDER TWO YEARS OF AGE TO BE RESTRAINED BY USE OF AN INFANT'S SAFETY SEAT. THESE SEATS MUST BE PROPERLY FITTED TO A STANDARD LAP BELT. CONSULT SEAT MANUFACTURER'S INSTRUCTIONS FOR PROPER SECURING OF THE SAFETY SEAT.

MANY STATES HAVE SPECIFICALLY OUTLAWED THE PRACTICE OF HOLDING INFANTS IN THE LAPS OF VEHICLE PASSENGERS.

When using seatbelts, always take up any slack belt by pulling the excess strap through the adjusting system. Unlatch the belt by pulling up on the buckle.

Seat Belt Maintenance

SEAT BELT ASSEMBLIES SHOULD BE PERIODICALLY INSPECTED TO ASSURE THAT THEY HAVE NOT BECOME DAMAGED AND THAT THEY REMAIN IN PROPER OPERATING CONDITION, PARTICULARLY IF THEY HAVE BEEN SUBJECTED TO SEVERE STRESS.

Fire Safety

Prevention is the best form of fire safety. Carefully follow the instructions for the care and operation of the var-

ious appliances in your vehicle (see appropriate sections).

Follow the same basic rules of fire prevention that you use at home. DO NOT SMOKE IN BED. DO NOT OVERLOAD THE ELECTRICAL SYSTEM. DO NOT PERMIT CHILDREN NEAR THE LP GAS CONTROLS OR CONTAINER. DO NOT STORE FLAMMABLE LIQUIDS INSIDE THE UNIT.

Carry-over your fire preparedness from home to your RV by having a pre-planned escape route. BE SURE EVERYONE KNOWS WHERE THE EMERGENCY EXITS ARE LOCATED AND HOW THEY OPERATE.

Your RV has been equipped with a fire extinguisher. MAKE SURE EVERYONE KNOWS WHERE IT IS LOCATED, HOW TO OPERATE IT AND WHAT TYPES OF FIRES IT IS DESIGNED TO HANDLE.

Check the extinguisher on a regular basis to make sure it is charged.

Smoke Detector

All units are equipped with a smoke detector. Check its operation on a regular basis. If it does not check out, get it serviced immediately.

NOTE: IF A FIRE DOES START WITHIN THE UNIT, GET ALL OCCUPANTS OUT IMMEDIATELY. IF IT IS A SMALL FIRE, USE THE FIRE EXTINGUISHER. IF THE FIRE IS NOT QUICKLY PUT OUT, GET OUT OF THE VEHICLE. CONTACT THE FIRE DEPARTMENT. IF POSSIBLE, CLOSE THE LP GAS SERVICE VALVE. MOVE A SAFE DISTANCE FROM THE VEHICLE.

LP Gas Safety

WARNING:

SHUT OFF ALL LP GAS SYSTEMS BEFORE FILLING THE GASOLINE TANK.

LP appliances should never be operated while the vehicle is in motion.

If the pungent odor of LP gas is detected, immediately shut off the LP gas valve and check the LP gas label for further instructions. Your unit may be equipped with an LP GAS LEAK DETECTOR that will help you detect the presence of LP gas. However, this detector should not be relied upon solely; if you detect the smell of LP gas, shut off the gas valve immediately.

Check other sections of this manual for more information on the LP gas system.

Gasoline Tank Safety

WARNING:

MODERN FUEL SYSTEMS MAY BUILD UP VAPOR PRESSURE WITHIN THE GASOLINE TANK AS THE

GASOLINE WARMS DURING VEHICLE USE AND DURING HOT WEATHER. UNDER CERTAIN CONDITIONS THE SUDDEN RELEASE OF THIS BUILT-UP PRESSURE BY THE REMOVAL OF THE GASOLINE CAP CAN SPRAY GASOLINE FROM THE FILLER OPENING, CREATING A POTENTIAL HAZARD.

WHEN REMOVING THE GASOLINE FILLER CAP, ROTATE IT SLOWLY TO ALLOW ANY INTERNAL PRESSURE TO BE SLOWLY RELEASED. AFTER THE "WHOOSH" OF THE RELEASED PRESSURE PASSES, COMPLETELY REMOVE THE CAP.

ALWAYS REPLACE A LOST GAS CAP WITH A CAP OF THE SAME DESIGN TO FORESTALL ANY ADDED PROBLEMS.

VEHICLE LOADING

Carrying Capacity

During the design and development of our motor homes, the number and size of storage compartments and the liquid tank capacities are maximized for value and convenience. If the motor home operator fills all liquid tanks to capacity, fills all storage compartments and cupboards to maximum volume and fills all available seating positions with passengers, the motor home will probably be overloaded. According to National Highway Traffic Safety Administration figures, an average vehicle occupant weighs 150 pounds, each gallon of gasoline weighs six pounds and each gallon of water weighs over eight pounds. The operator is responsible for analyzing the conditions in which the motor home will be utilized for each trip.

The number of passengers and placement of cargo will affect the amount of water and cargo that you can carry. The passenger capacity will vary depending on whether the vehicle is being used for overnight camping or day use. A smaller passenger capacity for camping will provide reasonable cargo capacity for trips taking more than one day. The passenger capacity for day use can be larger providing that less cargo is carried for trips and activities not involving overnight stays. It may be necessary to reduce the amount of water carried and unload some cargo items normally carried for camping in order to provide carrying capacity for the additional 1 (one) day use passengers.

Thoughtful consideration of the weight placed in the motor home can yield important benefits:

- maximum flexibility in the use of the liberal storage facilities provided in the motor home;
- improved handling characteristics and ride comfort;
- better fuel mileage and reduced tire wear.

Periodically reweigh your motor home. Different traveling configurations may change your loading and weight pattern.

WARNING: DO NOT EXCEED THE RATED LOAD OF

THE MOTOR HOME, OR THE RATED LOAD OF ANY AXLE.

NOTE: THE CARRYING CAPACITY OF YOUR MOTOR HOME CAN BE DETERMINED BY WEIGHING, AS SHOWN IN FIG. 2. THE SHIPPING WEIGHT DOES NOT INCLUDE OPTIONS SUCH AS LEVELING JACKS, AWNINGS, ROOF PODS, ETC. THE WEIGHT OF THESE ITEMS MUST BE SUBTRACTED FROM THE TOTAL OF THE PASSENGER AND CARGO CARRYING CAPACITIES. IF YOU TOW A TRAILER, THE TONGUE WEIGHT OF THE TRAILER MUST BE SUBTRACTED FROM THE TOTAL OF THE PASSENGER AND CARGO CARRYING CAPACITIES.

Notice: Empty all holding tanks before filling fresh water tank otherwise you will limit cargo and/or passenger capacity. Normally campgrounds supply free dump stations which can be utilized.

Loading Tips

After you have determined how much weight you can safely carry and selected those items to make up that weight, make a list and keep it for future reference. Load the motor home and distribute the load so that you get proper weight on the axles. Do not load upper cabinets with heavy items. Secure and brace items so they won't move during travel, thereby shifting the load in the motor home. Do not load heavy items near either end of the motor home or on the rear bumper. Adjust cargo storage to keep the side to side wheel loads as equal as possible. Carry only as much water as needed for travel use or to balance the load. Whenever possible, empty the holding tanks before traveling.

WARNING: DO NOT INSTALL ANY TYPE OF WEIGHT CARRYING RACK OR FRAME TO THE REAR BUMPER OR ANY CHASSIS OR BODY COMPONENT OF THE MOTOR HOME. DAMAGE TO THE MOTOR HOME BODY AND UNSTABLE HANDLING CHARACTERISTICS MAY RESULT.

WARNING: EXCEEDING THE GAWR OR GVWR OF YOUR MOTOR HOME CAN CAUSE UNDESIRABLE HANDLING CHARACTERISTICS AND MAY CREATE A SAFETY HAZARD. MODIFICATION OF YOUR VEHICLE BY ADDITION OF RACKS NOT SPECIFIED BY THE MANUFACTURER TO CARRY ADDITIONAL EQUIPMENT OR VEHICLES IS NOT RECOMMENDED, MAY CREATE A SAFETY HAZARD, AND MAY VOID YOUR WARRANTY.

Make a loading diagram of your properly loaded motor home. It will help you locate where specific items are stored, and will help speed the loading process. Store emergency items in a readily accessible location. Include tools, first-aid kit, rain gear, flashlight, highway warning devices, and an electric cord with light.

The difference between the empty weight and the weight of the motor home in traveling configuration is your usable load. If the loaded weight of your motor home exceeds the GVWR or the weight on any axle exceeds

that axle's GAWR, the motor home is overloaded and you'll have to remove items to bring the weight down to or below the GVWR and GAWR.

All items must be considered for their weight and stored according to how heavy they are. Heavy items should be placed close to the floor and in the center of the vehicle. **DON'T FORGET TO INCLUDE THE ITEMS YOU PURCHASE ON YOUR TRIP.**

Luggage and similar cargo carried inside the vehicle must be secured to prevent possible damage in the case of a sudden stop or an accident. It is no good to survive the initial impact of an accident to be hit on the head by a flying object from inside your vehicle.

Manufacturer's Labels

Your vehicle is equipped with several federally-required labels pertaining to the vehicle's weight, load capacity and operating limitations.

On the wall above the driver is the federal sticker that lists the unit's manufacturer's serial number, the front and rear GROSS AXLE WEIGHT RATING (GAWR), the vehicle's GROSS VEHICLE WEIGHT RATING (GVWR), tire and wheel rim sizes, tire operating pressure, chassis serial number and the VEHICLE IDENTIFICATION NUMBER (VIN). (FIG. 1)

MFD BY  GULF STREAM COACH, INC.			
DATE OF MFGR	INC. VEH MFD. BY	DATE OF MFGR	GVWR
GAWR FRONT LBS.	WITH MINIMUM TIRES	RIMS	AT PSI COLD
GAWR INTERM. LBS.	WITH MINIMUM TIRES	RIMS	AT PSI COLD
GAWR REAR LBS.	WITH MINIMUM TIRES	RIMS	AT PSI COLD
SINGLE	DUAL	THIS VEHICLE CONFORMS TO ALL APPLICABLE FEDERAL MOTOR VEHICLE SAFETY STANDARDS IN EFFECT IN	
VEHICLE ID NO.		VEHICLE TYPE	GULF STREAM SERIAL NO.

(FIG. 1) FEDERAL STICKER

Federal Weight Definitions

GAWR: The allowable weight, INCLUDING CARGO AND PASSENGERS, which can be SAFELY supported by each axle. **GVWR:** The maximum permissible weight of your vehicle, INCLUDING CARGO, ALL OPTIONS, PASSENGERS, GASOLINE AND WATER. **GVW and GAW:** These weights are found by weighing the vehicle FULLY-LOADED. **GVW** is the actual weight of the vehicle loaded with all the standard and optional equipment, cargo and passengers. **GAW** is the weight of the fully-loaded vehicle that is SUPPORTED BY EACH AXLE.

Determining Weight and Weight Distribution

The total amount of weight carried by your vehicle is extremely important. It is critical that you weigh your vehicle prior to taking a trip in order to determine if you are within the weight limitations of the vehicle's suspension. CHECK THE WEIGHT. CHECK THE TIRE PRESSURE IN RELATIONSHIP TO THE WEIGHT. See the Federal Sticker for the needed information. (FIG. 2)

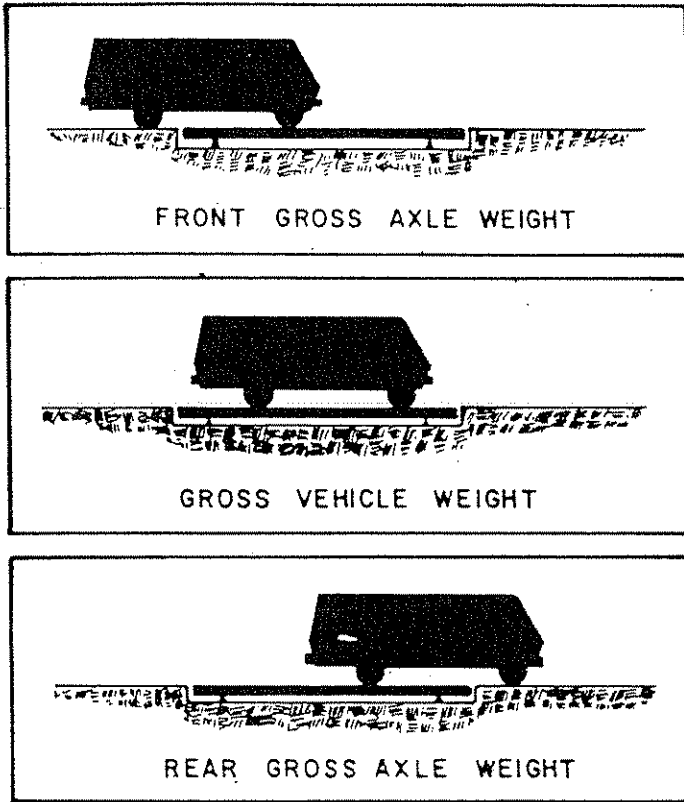

(FIG. 2) WEIGHING VEHICLE ON SCALES

The Method of Weighing Your Vehicle

There are many locations where you can weigh your vehicle including grain elevators, scrap iron businesses, sand and gravel dealers and state and federal weigh stations (listed in the Yellow Pages of phone directories across the nation).

NOTE: BE SURE TO WEIGH THE VEHICLE WITH EVERYTHING IN IT INCLUDING PASSENGERS, CARGO, FULL LP, GASOLINE AND WATER TANKS.

The procedure is as follows (unless modified by the weighmaster):

1. Drive only the front axle of the unit onto the scale. Have the weighmaster note this weight.
2. Drive forward and place both front and rear axles onto the scale. Have the weighmaster note this weight.
3. Drive forward until only the rear axle is on the scale. Have the weighmaster note this weight.

NOTE: COMPARE WEIGHT NUMBER 1 WITH THE VEHICLE'S GAWR LISTED ON THE FEDERAL STICKER. COMPARE WEIGHT NUMBER 2 WITH THE GVWR (MAXIMUM TOTAL VEHICLE WEIGHT) LISTED ON THE FEDERAL STICKER. FINALLY, COMPARE WEIGHT NUMBER 3 WITH THE GAWR FOR THE REAR AXLE LISTED ON THE FEDERAL STICKER.

If any weight exceeds the listed rating, relocate the passengers and redistribute or remove a portion of the cargo until the weight is within the proper limit as listed on the Federal Sticker and for which the vehicle has been engineered.

NOTE: DO NOT FORGET THAT WATER USED FROM THE FRESH WATER SUPPLY GOES INTO THE WASTE WATER HOLDING TANK. IF YOU REFILL THE FRESH WATER TANK PRIOR TO DUMPING THE WASTE WATER, THE WEIGHT OF THE VEHICLE IS SUBSTANTIALLY MORE THAN WHEN YOU WEIGHED IT AT THE START OF THE TRIP.

USEFUL WEIGHTS

Water	8.328 pounds per gallon
Gasoline.....	6.0 pounds per gallon
Propane	4.23 pounds per gallon

WEIGHT DISTRIBUTION FORMULAS

Inside Wheelbase: Number of inches behind front wheel divided by vehicle wheelbase.

Example for a 178 inch wheelbase: A tool chest is stored 36 inches behind the front wheel. Divided by the 178 inch wheelbase equals 20 percent of the tool chest's weight added to the rear axle and 80 percent to the front axle.

Outside Wheelbase: Determine the distance the object is from the nearest axle. Divide by the wheelbase.

Example: A motorcycle is hung on the rear bumper of an RV. It is 144 inches behind the rear axle. Divide the 144 by the vehicle's 178 inch wheelbase and you find that the motorcycle equals 80 percent more than its actual weight... in other words it acts on the vehicle as though it weighs 180 percent on the rear axle. THE EXCESS OF 100 PERCENT IS TAKEN OFF OF THE FRONT AXLE.

If the motorcycle weighs 300 pounds it acts on the RV as though it weighs 540 pounds! Two hundred forty pounds is also taken off of the front axle.

VEHICLE WEIGHT PLANNING GUIDE

MODEL NUMBER: _____
 UNIT NUMBER: _____
 CHASSIS MANUFACTURER: _____
 UNIT FACTORY BASE WEIGHT: _____ lbs.

OPTIONS*:	WT. LBS. (Approx.)
6.5 Generator	312
4.0 Generator	272
Roof Air Conditioner 13.5	98
Roof Air Conditioner 13.5	98
Roof Air Conditioner 11.5	92
Electric Step	29
Spot Light	6
Fog Lights	3
Dash Fans	2
TV Dash Overhead	18
Television	19
Video Tape Recorder	12
Goodyear Tires 8-19.5 Spare	95
Radial Tires 8-19.5 Spare	97
Mirrors	2
Pedestal Tables	22
Water Purifier	5
Instant Water Heater	3
Microwave Oven	60
Deluxe Barrel Chair	47
10 Cu. Ft. Refrigerator	12
Queen Bed Mattress	10
Twin Bed Mattress	5
Air Horns	24
OPTIONAL TOTAL:	_____
FUEL WEIGHT	
.....1/4 Capacity	_____
.....1/2 Capacity	_____
.....3/4 Capacity	_____
.....Full	_____
FUEL TOTAL	_____
FRESH WATER WEIGHT	
.....1/4 Capacity	_____
.....1/2 Capacity	_____
.....3/4 Capacity	_____
.....Full Capacity	_____
WATER TOTAL	_____
OCCUPANTS	
(150 LBS. EACH)	_____ LBS.
GVWR =	_____ LBS.
SUBTRACT COMBINED	
TOTAL WEIGHTS	
FROM ABOVE -	_____ LBS.
EQUALS VEHICLE NET	
CARRYING CAPACITY =	_____ LBS.

* If checked, indicates vehicle Base Weight includes this option. Add weight of any options added by dealer.

AIR BAG WARNING:

GULF STREAM COACH, INC., DOES NOT APPROVE THE USE OF AFTER MARKET SUSPENSION AIR BAGS ON ITS VEHICLES. AIR BAGS, WE HAVE DETERMINED, DO NOT PROPERLY SUPPLEMENT THE SUSPENSION. INSTEAD, THEY INTERFERE WITH THE RIDE AND HAN-

DLING OF CLASS A MOTOR HOMES AS ENGINEERED BY THE CHASSIS MANUFACTURER. GENERAL MOTORS ADVISES IN THEIR CHASSIS MANUAL THAT SUPPLEMENTAL AIR BAGS CAN BE DESTRUCTIVE TO THE VEHICLE AND INTERFERE WITH ITS ROAD HANDLING CAPABILITIES.

DO NOT USE SUPPLEMENTAL AIR BAGS ON YOUR MOTOR HOME. IF SUPPLEMENTAL CAPABILITY FOR THE SUSPENSION IS DESIRED, UPGRADE WITH ADDITIONAL SPRINGS, HIGHER CAPACITY SHOCK ABSORBERS OR COIL-OVER SHOCKS THAT ARE COMPATIBLE WITH THIS VEHICLE.

WE CANNOT APPROVE ANY AIR BAG INSTALLATION BEFORE MODIFYING YOUR SUSPENSION. TALK TO YOUR DEALER. AVOID CAUSING POSSIBLE DAMAGE TO YOUR MOTOR HOME.

Dangers of Overloading

One of the attractive selling points of the GULF STREAM is the abundance of storage, both inside and outside the vehicle. However, there are limits to what the vehicle can carry as has been shown above.

When preparing for a trip and while on your travels, always be mindful of WHAT YOU ARE STORING, HOW MUCH IT WEIGHS AND WHERE YOU ARE STORING IT. BEWARE OF OVERLOADING.

In addition to causing premature wear, overloading can cause problems in the area of handling characteristics. An overloaded vehicle will take longer (time and distance) to stop in an emergency. Overloading can also cause added wear to components such as tires, wheel bearings, transmission and engine.

The solution? Stay on top of your vehicle weight situation at all times. Know where you stand when it comes to GVWR and GAWR.

Vehicle Towing

Prior to towing any vehicle behind your motor home, be sure to consult your chassis manufacturer owner's manual. Determine what type of special equipment is needed to be able to tow with your motor home.

NOTE: IMPROPER USE OF YOUR UNIT AS A TOW VEHICLE MAY VOID YOUR CHASSIS WARRANTY AND MAY RESULT IN DAMAGE TO THE MECHANICAL PORTIONS OF THE CHASSIS.

Emergency Towing of the Motor Home

Extreme care must be taken in the event the unit must be towed as a result of a break down or accident.

NOTE: THE USE OF A "DOLLY"-TYPE TOW DEVICE THAT TOWS THE VEHICLE WITH ITS FRONT WHEELS SECURED ON A SMALL PLATFORM FITTED WITH ITS OWN SET OF WHEELS OR A WHEEL-LIFT TOWING DEVICE THAT CARRIES THE MOTOR HOME'S FRONT WHEELS IN A "CRADLE" OR "SLING" ARE THE ONLY METHODS RECOMMENDED.

PRE-TRIP CHECK LIST

EXTERIOR (At Home)

Check:

- All objects (mirrors etc.) secure _____
- Tires at proper pressure (spare) _____
(check for wear/damage)
- Wheel lug nuts at proper torque _____
- Hitch and hitch ball secure _____
- All exterior lights operational _____
(headlights, turn signals etc.)
- Windshield wiper blades etc. okay _____
(check operation)
- Batteries charged, fluid level okay _____
- Fluids topped off _____
(oil, brake, trans, anti-freeze/coolant)
- Belts and hoses in good condition _____
(check belt tension and clamps)
- Brakes checked for operation _____
(including emergency)
- Secure all compartment doors _____
(all stored items secure)
- Auxiliary generator compartment _____
(secure, oil level, leaks)
- Undercarriage secure _____
(exhaust system, drive train, leaks)
- Dumping station equipment _____
(secure, clean, working order)
- LP gas system secured _____
(tank level, check for leaks)
- Roof secure _____
(roof top carrier, antennae, a/c)
- Emergency equipment _____
(jack/wrench, blocks, flares etc.)

INTERIOR

Check:

- Antenna LOWERED/SECURED _____
- Roof vents LOWERED _____
- Refrigerator LOCKED _____
(operational/stocked)
- Water Heater OFF _____
(check operation)
- Water Pump OFF _____
(check operation/leaks)
- Fresh Water Holding Tank Level _____
(sanitized)

- Waste Water Holding Tank Level _____
(dumped, chemicals)
- Toilet _____
(operation/supplies)
- Furnace OFF _____
(check operation)
- Stove Pilot OFF _____
(check operation)
- LP Gas System SECURED _____
(check for leaks)
- Cooktop Cover CLOSED _____
- Drawers, Closets, Windows CLOSED _____
- START ENGINE _____
(check operations: temp, pressure, idle,
charging etc.)
- Horn _____
- CB (Optional) _____
- Radio/Cassette Player _____
- Seat (adjustments) _____
- Mirrors (adjustments) _____
- Transmission _____
- Brakes _____
- Dashboard lights _____
- Driver's door _____
- Gas Gauge (level) _____
- Maps/Camp reservations _____
- Owner's Manuals/Warranty Papers _____

PRE-TRIP CHECK LIST — CAMPSITE

FOLLOW THE ABOVE CHECK LIST WITH THESE ADDED POINTS:

EXTERIOR

- Disconnect all shore lines _____
(City Water, Electric, Sanitary)
- Remove blocks/wheel chocks _____
- Retract Step _____
- Store/Secure camping equipment _____
(deck chairs, bicycles etc.)

CHECK CLEARANCES PRIOR TO PULLING OUT

DAY-TO-DAY OPERATION

DRIVING

With just a few miles under your belt, you will find that your new GULF STREAM handles much like a quality automobile. However, you must take into consideration that the vehicle is much longer, higher and heavier than any car or light truck.

Always be mindful of your vehicle's height when approaching underpasses, awnings, parking garages, drive-in facilities (banks, food, fuel) and carport-type overhangs. Remember: your vehicle's height can be different than what the manufacturer lists depending upon any additions you have added to the roof.

NOTE: WHEN APPROACHING AN OVERHANG THAT IS APPROXIMATELY THE SAME HEIGHT AS YOUR UNIT, USE EXTREME CAUTION. PAVEMENT DIPS/RISES AND NEW LAYERS OF ROAD SURFACE CAN MAKE OLD CLEARANCE SIGNS OBSOLETE. "WHEN IN DOUBT ... STAY OUT."

Just as overhangs can produce problems, so do dips and rises in pavement. Be extremely cautious when entering and leaving the main roadway (drives, parking lots, side roads). Become familiar with the rear overhang characteristics of your individual unit. This will help you avoid damage to the undercarriage behind the rear axle.

DRIVER CONTROLS

Tilt Steering Wheel

Your unit may be equipped with a tilt steering wheel that can be moved to allow additional room for entrance and exit from the driver's seat and also adjust to your driving style. (FIG. 3). Consult your Chassis Owner's Manual for further information.

Cruise Control

Your vehicle may be equipped with Cruise Control/Auto Speed Control. Refer to the Cruise Control owner's manual for details on its operation. Figure 4 depicts a typical cruise control.

Seat Adjustment

See Furnishings, page 21.

Brakes

As mentioned previously, your vehicle is much larger than an automobile and, although equipped with well-engineered brakes, is likely to take more distance to stop than you have been accustomed to in the past with autos. Learn how quickly your vehicle will stop from your normal

cruising speed with the loads you carry. Become familiar with the amount of pressure that it takes to "lock-up" the brakes in a "panic" stop.

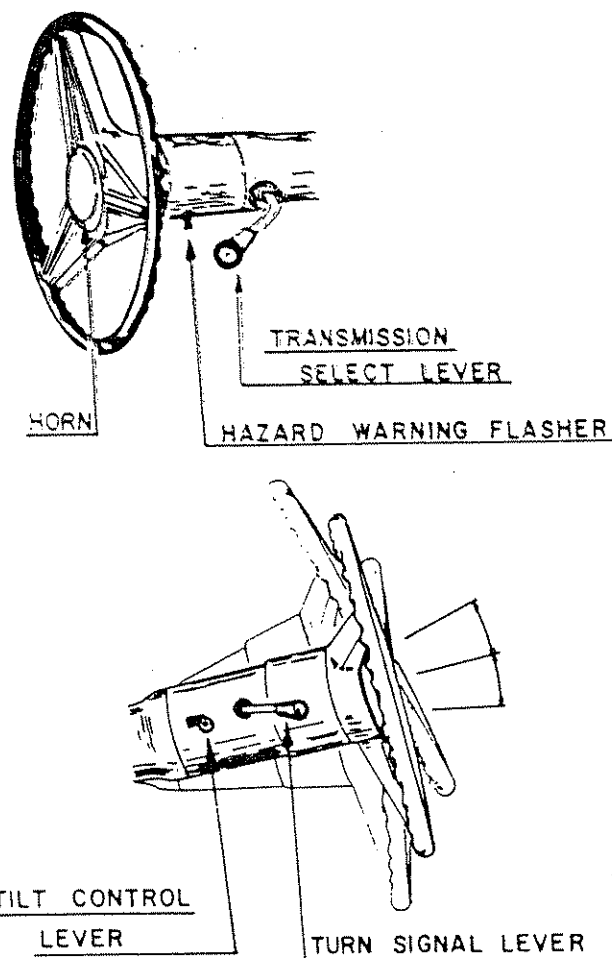

(FIG 3) TILT STEERING WHEEL

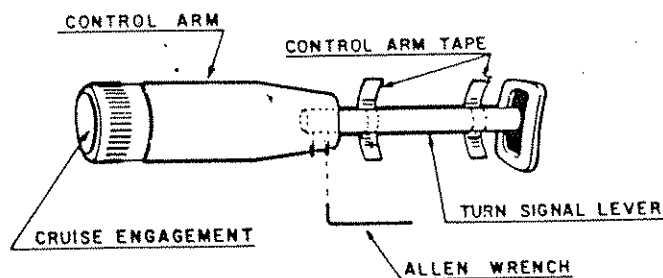

(FIG 4) CRUISE CONTROL

NOTE: EVEN MODERN DISK BRAKES WILL NOT STOP A VEHICLE INSTANTLY IF THEY HAVE BEEN SUBMERGED IN WATER. BE CAREFUL WHEN DRIVING IN FLOODED CONDITIONS. "PRE-DRY" BRAKES PRIOR TO THEIR BEING NEEDED BY LIGHTLY PRESSING DOWN ON THE BRAKE PEDAL AND ENGAGING THE BRAKE PADS AND SHOES TO GET RID OF EXCESS WATER AND WARM THE BRAKING SURFACES. EXTREME CAUTION IS ALSO NEEDED IF ONLY ONE SIDE OF THE VEHICLE'S BRAKING SYSTEM HAS BEEN

FLOODED. IF A STOP IS NEEDED THE VEHICLE COULD VEER TO THE SIDE THAT IS DRY (THE BRAKES ON THAT SIDE OF THE VEHICLE ARE WORKING MUCH BETTER THAN THE WET SIDE).

If you notice that the brakes get "mushy", take your unit to your nearest dealer for inspection. Unusual sounds during braking may indicate a problem. Have your dealer check the braking system. Read your chassis owner's manual for further information on your particular braking system and its care.

Dashboard Instruments

While driving, always be attentive to your vehicle's dash instruments. These instruments are designed to warn you of any problem or potential problem with the vehicle. It is best to stop the vehicle at once if any warning light appears.

Reduce your speed immediately by lifting off of the throttle. CHECK THE TRAFFIC BEHIND YOUR UNIT. Don't apply the brakes too rapidly. SIGNAL YOUR INTENTIONS.

Quickly, safely pull off to the side of the roadway onto a safe, solid shoulder area. Make sure the vehicle is out of the flow of traffic as much as possible. Shut down the motor. Place the transmission into PARK and apply the PARKING BRAKE. Put on your emergency flashers. Investigate the problem ... more than likely under the hood.

NOTE: IT IS A GOOD PRACTICE TO PLACE FLARES AT INTERVALS SEVERAL YARDS BEHIND THE VEHICLE. ESPECIALLY IF YOU HAVE STOPPED AT A HILL, CROSSING OR CURVE. STAND-UP TRIANGULAR REFLECTORS ARE ALSO QUITE WORKABLE. IF THE VEHICLE IS STOPPED JUST OVER THE RISE OF A HILL OR JUST PAST A CURVE, PLACE FLARES OR REFLECTORS OVER OR AROUND THE OBSTACLE TO WARN ON-COMING TRAFFIC IN PLENTY OF TIME FOR THEM TO SLOW DOWN PRIOR TO REACHING YOUR STOPPING POINT.

WARNING:

BE EXTREMELY CAREFUL WALKING ON THE SHOULDER NEAR YOUR VEHICLE AT NIGHT. MANY PEOPLE ARE KILLED EACH YEAR BY MOTORISTS WHO WANDER ONTO THE SHOULDER AT NIGHT. IN SOME RURAL AREAS OF THE COUNTRY IT IS THE CUSTOM ON TWO-LANE ROADS FOR SLOWER TRAFFIC TO DRIVE ON THE SHOULDER SO FASTER VEHICLES CAN PASS WITHOUT HAVING TO MOVE INTO THE ON-COMING TRAFFIC LANE. THIS CAN CAUSE PROBLEMS IF THE DRIVER ON THE SHOULDER IS NOT PAYING PARTICULARLY GOOD ATTENTION TO WHAT'S ON THE SHOULDER WELL AHEAD OF HIM.

If a warning light does come on, check under the hood for possible problems:

1. If the OIL PRESSURE WARNING LIGHT comes on:
 - * Check motor oil level. Add oil if needed.
 - * Check motor oil condition ... water in oil will look "milky." PARK IT.
 - * Check for leaks under vehicle and over engine. If large leaks ... PARK IT.
 - * If oil level and condition check out okay and there are no major leaks or smoking, proceed slowly to nearest mechanic for a check.
2. If the COOLANT TEMPERATURE LIGHT comes on:
 - * Check under hood for split or leaking water hoses and loose hose clamps.
 - * When cooled down, check coolant level. Add coolant (or water in an emergency) if needed. Proceed with caution after filling or upon finding nothing obviously out of sorts.

WARNING:

NEVER ATTEMPT TO OPEN A RADIATOR CAP WHEN THE ENGINE IS OVERHEATED OR EVEN AT NORMAL OPERATING TEMPERATURE. THIS WILL RESULT IN AN "EXPLOSION" OF BOILING COOLANT FROM THE RADIATOR OPENING THAT CAN RESULT IN SERIOUS INJURY TO ANYONE STANDING NEARBY.

EXPEDITIOUS USE OF YOUR NOSE WILL OFTEN TELL YOU WHETHER OR NOT YOU HAVE A HEATING PROBLEM. IF YOUR NOSE SAYS "SOMETHING IS COOKING" THEN BELIEVE IT UNTIL YOU PROVE OTHERWISE. EXTREMELY HOT COOLANT HAS A DISTINCTIVE SMELL IF THERE IS A LEAK IN THE SYSTEM. CAREFULLY USE YOUR SENSE OF TOUCH TO SEE IF YOUR COOLANT SYSTEM IS OVERHEATING. CAREFULLY TOUCH THE HOSES AND THE TOP OF THE RADIATOR TO SEE IF IT IS HOTTER THAN IT SHOULD BE UNDER THE CONDITIONS (COLD WEATHER, HOT WEATHER ETC.).

STAY AWAY FROM ANY STEAM ESCAPING FROM SPLIT HOSES, FAILED GASKETS OR LOOSE CLAMPS. WHEN THE VEHICLE HAS COOLED, THEN ATTEND TO THE PROBLEM.

Two-Speed Cooling Fan Noise

Some chassis are equipped with a two-speed engine cooling fan. According to manufacturer's research, the engine of your RV uses the fan at its low, quieter speed 95 percent of the time. Only during instances where extra cooling is needed will the fan run at its higher, louder speed. Speed control is through a temperature sensitive fluid clutch.

The higher, louder fan speed does not necessarily coincide with engine speed. The engine may be at or near idle, while the fan is at its top speed and making quite a bit more noise than it does 95 percent of the time. Or it may turn to the higher speed during a drive up an incline.

The reason that the unit has a two-speed fan is that, while noise reduction is important, the lower fan speed also reduces the horsepower needed to turn the fan, thus the lower speed saves fuel.

Unused Dashboard Switches

As a result of the optional equipment available on our extensive line of vehicles, each unit is somewhat different than other units built with the same standard dashboard. Therefore, on some RV models certain dashboard switches will not have a function when delivered, however, many of these unused switches can be adapted by you and your RV dealer for use with options added after delivery. Consult your dealer representative for details.

Starting and Vehicle Warm Up

Check your chassis manufacturer's owner's manual for details on starting your vehicle on COLD or HOT days.

Important Operating Instructions for Turbo Charged Diesel Engine

This turbo charged engine and turbo charger operate at very high temperatures which provide the fuel efficiencies, high horsepower, and necessary emission standards. Because of this, the engine must be allowed to build up heat slowly and cool slowly to prevent expansion and contraction of internal engine and turbo charger components. This is accomplished by the following:

Starting

Once the engine starts, return the accelerator pedal to the idle position and let the engine idle for 3 to 5 minutes before applying a load.

Shutting Down

If you have been driving at highway speeds, allow the engine to idle for 3 to 5 minutes before shutting it off. This allows the engine to cool gradually and uniformly.

Jump Starting

If you encounter a dead battery or a low battery and cannot get the vehicle started on its own, you may need to get a jump start. Certain safety precautions need to be taken.

1. Be sure the jumper cables are in good condition with no exposed wires that may cause a short.
2. If possible check all batteries for fluid level. BE CAREFUL OF OPEN FLAMES AROUND BATTERY FUMES. THERE IS A CHANCE OF COMBUSTION.
3. Route the cables in such a manner as to avoid all pulleys and belts.
4. Set the RV parking brake; place the vehicle's transmission into PARK. Turn off the ignition and all electrical items.
5. Use only 12-volt battery grounded the same as your vehicle (+ or -). DO NOT USE A 24-VOLT SYSTEM TO JUMP START. THIS CAN CAUSE DAMAGE TO YOUR ELECTRICAL SYSTEM.
6. DO NOT LET VEHICLES TOUCH.
7. Attach one end of a cable to the positive (+) terminal of the booster battery and the other end of the same cable to the positive terminal of your vehicle's battery.
8. Attach an end of the other cable to the negative (-) terminal of the booster battery and its opposite end to a solid ground in your vehicle's engine compartment at least 18 inches from the dead battery. DO NOT ATTACH IT TO THE NEGATIVE POST OF THE DEAD BATTERY.
9. Start the engine of the vehicle that is providing the boost and turn off all electrical accessories. Now start the vehicle with the dead battery. If the engine in the vehicle with the dead battery does not want to turn over very easily, check the connections and also see that there is no drain on the electrical system.
10. After the dead battery vehicle has started, carefully disconnect the battery cables, making sure not to get them tangled in the moving parts of the running engines. Disconnect the negative ground contact on the dead battery car first. After the negative cable has

been removed from both cars, disconnect the positive terminal on the dead battery car first. See Alternator Warning section.

WARNING:

WHEN JUMP STARTING, BE EXTREMELY CAUTIOUS. BATTERIES, UNDER CERTAIN CONDITIONS DURING JUMP START PROCEDURES, CAN EXPLODE SPREADING BATTERY ACID OVER A WIDE AREA. THIS ACID IS VERY HARMFUL TO HUMANS AND AUTOMOTIVE FINISHES. IF YOU OR ANYONE WITH YOU GETS BATTERY ACID ON THEIR PERSON, FLUSH EXPOSED SKIN, EYES IMMEDIATELY WITH A LARGE AMOUNT OF WATER. SEEK A PHYSICIAN IN MAJOR CASES, AND WHERE THE EYES HAVE BEEN CONTAMINATED, FLUSH ANY RV BODYWORK UNIT THAT COMES INTO CONTACT WITH THE ACID.

EVEN WORKING WITH AN OLDER BATTERY THAT HAS SOME CORROSION ON THE TERMINALS (SUCH AS THE BOOSTER CAR/BATTERIES) CAN GET ENOUGH ACID PARTICLES ON YOUR HANDS TO CAUSE PAIN/IRRITATION. BE SURE NOT TO PUT FINGERS IN EYES, ON FACE OR IN YOUR MOUTH (AS IN PULLING A GLOVE OFF YOUR HAND WITH YOUR TEETH), WASH HANDS EXTREMELY WELL AFTER COMPLETING THE JUMP START.

Jump Starting Tip (GM Chassis)

IN THE CASE WHERE THE RV UNIT'S AUTOMOTIVE BATTERY HAS GONE DEAD (OR THE AUXILIARY BATTERY IS LOW TO DEAD) AND YOU JUMP START THE VEHICLE, THE VEHICLE'S ELECTRICAL SYSTEM WILL REACT IN SUCH A MANNER (GOING TO FULL CHARGE) AS TO BLOW THE 20 AMP IGNITION FUSE. THIS IS BECAUSE THE ALTERNATOR JUMPS TO "FULL CHARGE" (OVER 90 AMPS) AND BLOWS ITS OWN FUSE TO PROTECT ITSELF (SEE SECTION ON AUXILIARY STARTS). THE AMP GAUGE WILL READ "0" CHARGE ... AS IF EVERYTHING IS NORMAL ... YET THE DEAD AUTOMOTIVE BATTERY NEEDS TO BE CHARGED. NO MATTER HOW MUCH YOU DRIVE THE VEHICLE, THE DEAD BATTERY WON'T BE CHARGED. YOU'LL BE RUNNING ONLY ON WHAT LITTLE CHARGE WAS GIVEN TO THE BATTERY AT THE TIME OF THE JUMP ... NOT MUCH AT ALL.

YOU MIGHT GO AND GET THE AUTOMOTIVE (CHASSIS) BATTERY CHARGED, SINCE YOU KNOW IT WENT DEAD, BUT FROM THAT POINT ON, THE ALTERNATOR WON'T BE ABLE TO CHARGE. THE BATTERY WILL SOON BE DRAINED AGAIN.

THE PROBLEM IS THAT THE IGNITION'S FUSE IS BLOWN. UNLESS AN INDIVIDUAL KNOWS THAT THE FUSE IS BLOWN, A MECHANIC MIGHT REPLACE WHAT HE THINKS IS A DEFECTIVE ALTERNATOR (WHEN TESTED IT WON'T CHARGE). A NEW ALTERNATOR MAY BE HARD TO COME BY AND COSTS WELL OVER \$100. THE IGNITION FUSE COSTS LESS THAN ONE DOLLAR!

VEHICLE SYSTEMS

Safety

Your new vehicle has been provided with numerous safety features.

EMERGENCY WINDOW EXIT: Push on bottom tab. Window will swing out, held in place by top-mounted hinges.

FIRE EXTINGUISHER: Located in forward driver's compartment. Activated by pulling ring-pin and squeezing handle. Direct contents at base of fire. Read instructions on bottle. Check regularly to insure that charge is adequate.

SMOKE DETECTOR: Located in kitchen/dining area. Sounds alarm if it detects smoke. Test regularly and replace battery as needed. Consult smoke detector owner's manual.

SAFETY BELTS: Seats that are designed to be used while the vehicle is in motion are equipped with lap/shoulder belts. Flat metal section fits into buckle and locks, giving a distinctive "click." Unlock by pulling up on the buckle.

WARNING/HAZARD FLASHERS: Activated by pushing in button on steering column. Parking/turn signal lights flash on and off. Use when vehicle stopped for emergency on roadside.

EMERGENCY PARKING BRAKE: Activated by pushing down with foot the lever that is located on the left side of the steering column below the dashboard. Release by pulling the **EMERGENCY BRAKE RELEASE HANDLE**, located just above the **EMERGENCY BRAKE**.

NOTE: SOME CHASSIS MANUFACTURERS DO NOT PROVIDE AN EMERGENCY BRAKE OF THIS TYPE. CONSULT CHASSIS OWNER'S MANUAL FOR DIRECTIONS ON HOW TO USE THESE SPECIFIC EMERGENCY BRAKE SYSTEMS.

Use the brake anytime the vehicle is parked and also in the event the main brake system fails. It would be advantageous to test the effectiveness of the **EMERGENCY BRAKE** in stopping the vehicle at various speeds. **BE CAREFUL NOT TO APPLY THE EMERGENCY BRAKE TOO FAST/HARD. WATCH FOR TRAFFIC BEHIND YOU.**

ELECTRICAL

Your **GULF STREAM** is equipped with two separate electrical systems that provide your vehicle with power on the road and in camp.

12-volt 110-volt

Like all vehicles, it has a 12-volt system that is used for running the vehicle's motor and accessories as well as other added RV equipment that's designed for 12-volts. This is a direct current (DC) system (12V).

Like your home, the vehicle has a 110-volt alternating current (AC) system that requires an external source of 110-volt electricity. This can be provided for by a shoreline connection (extension cord) or an optional electrical on-

board power generator. In order to use your 110-volt electrical system, your shoreline (power cord) should be plugged into either an external power source or the generator slater receptacle located in the shoreline storage compartment. 110-volt current is made available to you through the electrical outlets placed throughout the vehicle. **TO CONSERVE BATTERY POWER, USE OF THE SHORELINE IS RECOMMENDED WHENEVER POSSIBLE. (FIG. 5)**

Consult your generator manufacturer's owner's manual for further details on its use and maintenance.

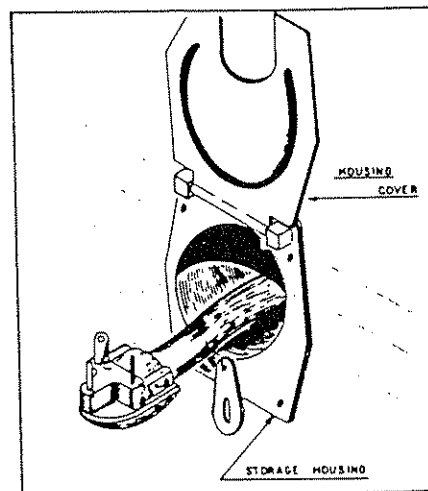

(FIG. 5) 110-V SHORELINE CONNECTION (TYPICAL)

DO NOT USE A CHEATER PLUG (ONE WITH THE GROUND WIRE PIN REMOVED) TO HOOK UP YOUR MOTOR HOME TO A 110 VOLT CIRCUIT.

DO NOT USE AN EXTENSION CORD WITH A CURRENT RATING OF LESS THAN 30 AMPS TO PLUG INTO AN ELECTRICAL OUTLET THAT IS BEYOND THE REACH OF YOUR MOTOR HOME'S POWER CORD.

Power Converter

Your vehicle is equipped with an electrical power converter that changes 110-volt power to 12-volt power to run the appliances in your vehicle. It gets the 110-volt power by way of the shoreline or the optional power generator. On most vehicles the unit is located at the bottom of the wall panel on the left side of the side door entrance (FIG. 6).

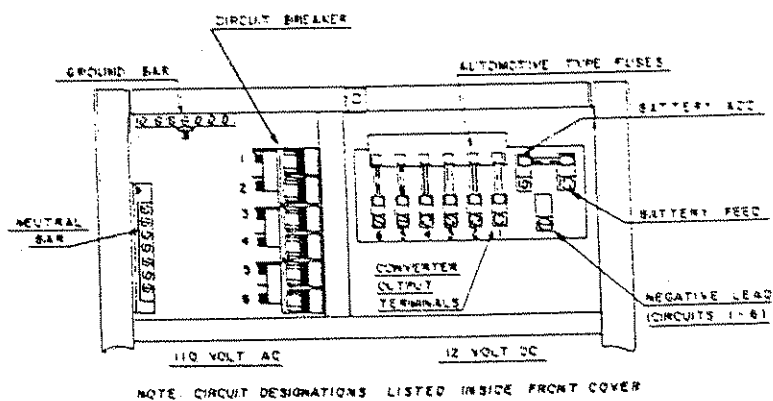

(FIG. 6) 45 AMP CONVERTER PANEL (TYPICAL)

The circuits in the vehicle are protected by circuit breakers and fuses. Locate the converter and see where the fuses are located. If you blow a fuse, turn off the appliance. Unplug it. Check the fuse for that circuit and replace with a new fuse of the proper rating. If the fuse continues to fail, contact your nearest dealer. (FIG. 7).

NOTE: SOME FUSES HANDLE MORE THAN ONE FUNCTION.

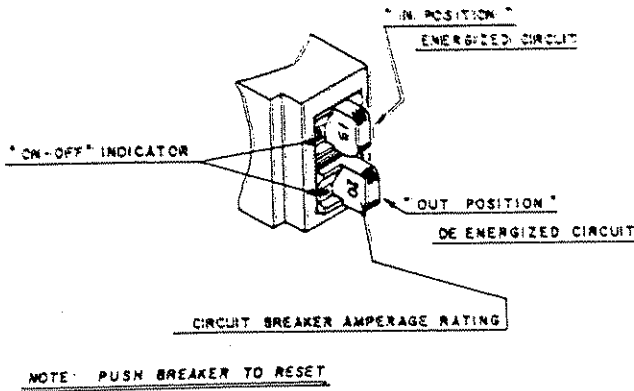

(FIG. 7) CIRCUIT BREAKER RESET

Ground Fault Interrupter

Your unit is equipped with a Ground Fault Interrupter that will stop the current in the event of a short. Refer to your manufacturer's owner's manual for instructions on how to reset the GFI. (FIG. 8)

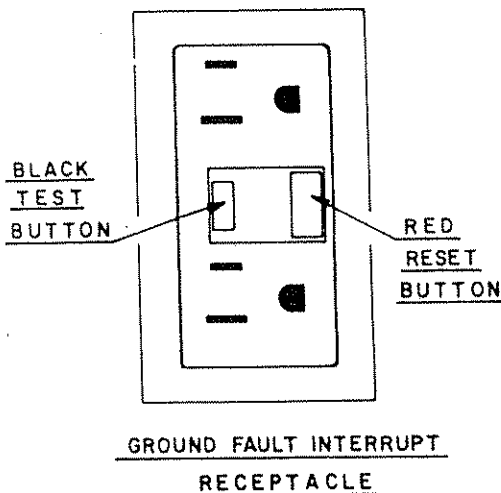

(FIG. 8) GFI RECEPTACLE

Automotive 12-Volt System

The vehicle's alternator provides power to charge both the automotive 12-volt battery and the auxiliary 12-volt RV battery. An isolator prevents the RV battery from draining the automotive battery. (FIG. 9)

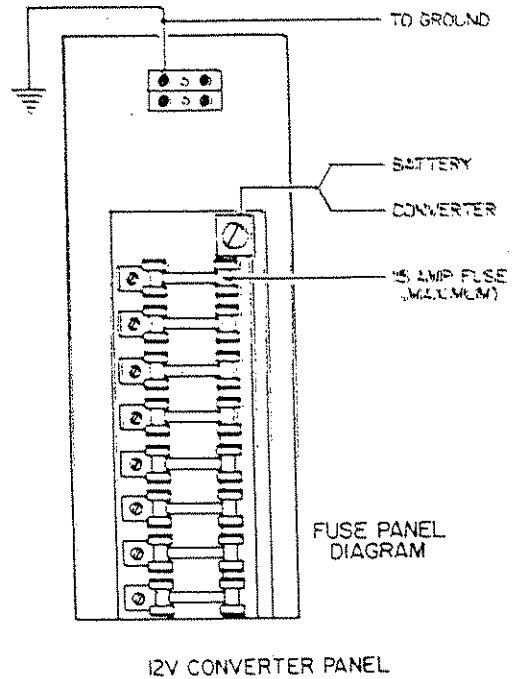

(FIG. 9) AUTOMOTIVE 12-VOLT SYSTEM (TYPICAL)

The automotive battery provides power to start and run the vehicle's ignition system and power the various automotive lights.

The alternator charges the RV Battery that, in turn, powers all the appliances and equipment in the vehicle that use 12-volt. These include the furnace blower, refrigerator (if your unit has a 3-way type) and the water pump. The RV Battery is charged through the power converter whenever the vehicle is using a shoreline connection or when a generator is used.

NOTE: KEEP IN MIND WHAT APPLIANCES/EQUIPMENT YOU HAVE TURNED ON WHEN YOU ARE WORKING OFF OF THE RV BATTERY ALONE. SOME EQUIPMENT DRAINS POWER AT A MUCH GREATER RATE THAN OTHERS.

Battery

As noted above, the unit has two or more batteries aboard. Both are maintained in the same manner. Check the electrolyte fluid levels on a regular basis, especially during hot weather conditions. Refill as necessary with either distilled water or clean tap water in an emergency. **DO NOT ALLOW THE FLUID LEVELS IN THE BATTERIES TO FALL BELOW THE INTERNAL BATTERY PLATES. DAMAGE TO THE BATTERIES MAY RESULT AND SHORTEN THE LIFE OF THE BATTERIES.**

When charging the batteries, do not charge at such a fast rate as to cause spewing of the electrolyte from the cells. However, do charge the battery with the cell vent caps off.

WARNING:

NEVER USE AN OPEN FLAME AROUND BATTERIES. AVOID MAKING ELECTRICAL SPARKS. FUMES FROM THE BATTERY ARE COMBUSTIBLE.

KEEP AN EYE OUT FOR CORROSION ON THE BATTERY TERMINALS. CORRODED TERMINALS CAN CAUSE A LOSS OF AVAILABLE POWER AS WELL AS CUT DOWN ON THE EFFICIENCY OF THE CHARGING/ELECTRICAL SYSTEM. THIS COULD LEAD TO A SITUATION WHERE THE BATTERY ISN'T CHARGED ENOUGH TO START THE VEHICLE ... THE DRAIN ON THE BATTERY WAS GREATER THAN THE CHARGE TO THE BATTERY DUE TO DIRTY TERMINAL CONNECTIONS

If your batteries have problems prior to the end of their warranty period, consult the nearest representative of the battery manufacturer.

When it is time to replace the batteries, be sure to replace them with quality batteries of equal electrical and physical properties. Contact your nearest dealer for advice in the selection of new batteries.

On-Board Auxiliary Power Generator (Optional)

This unit provides 110-volt power to the converter as well as charges the RV battery. Read over the manufacturer's owner's manual for the unit's operation and care/maintenance.

The unit runs on gasoline provided to it by a fuel line from the RV's gas tank. BE SURE TO CHECK THE OIL LEVEL OF THE GENERATOR AT REGULAR INTERVALS.

Fuse Boxes

Your vehicle is equipped with two fuse "boxes" that guard the electrical system. The fuses that protect the automotive systems are located on the driver's compartment firewall base. The other "box" protects the remainder of the RV systems and is located under the hood on the engine compartment's firewall just in front of the driver.

In the event of a fuse failure check the fuse box inside the vehicle or under the hood. Replace any blown fuse with new fuse of the same amperage. DO NOT REPLACE WITH A HIGHER AMPERAGE FUSE. THIS CAN RESULT IN AN ELECTRICAL FIRE.

Monitor Panel

Your vehicle has an electrical panel that can provide you with important information about various systems on your RV including the condition of your batteries.

The panel is most often located on the wall to the left of the side entrance above the electrical converter. If your vehicle does not have a wall at this location, then the panel will be in the kitchen area on a side panel.

MONITOR PANEL – The lights will illuminate when the proper button has been pushed. The MONITOR PANEL can, with the touch of a finger, inform you of the condition or status of several systems incorporated into your vehicle.

The top row of small red lights indicates the status of various holding tanks when the proper switch is pushed.

The lights inform you (left to right) that the tank is either empty, one-quarter, one-half, three-quarters or completely full.

The second row of small lights indicates (left to right) that the battery condition is either low (red), fair (light green) or good (dark green) when the battery condition switch is pushed. The extreme left light (red) indicates the water pump is getting electricity when its switch is activated.

The rocker switches along the bottom of the panel only work when pushed "in" and automatically return to "off" when released.

The rocker switch on the extreme left indicates HOLDING TANK 1 when pushed on the left side and HOLDING TANK 2 when pushed on the right side.

The rocker switch second from the left indicates the water level of the POTABLE WATER TANK.

The second from right rocker switch is for the RV BATTERY CONDITION.

Television Electrical Connection

A television "cigarette lighter" type DC electrical outlet is located in your vehicle. For example, on some units it is located on the passenger side beneath the dashboard on the sidewall just above the floor. THIS "CIGARETTE LIGHTER" OUTLET IS INTENDED FOR TELEVISION USE ONLY. ANY OTHER USE MIGHT CAUSE AN ELECTRICAL PROBLEM OR A POSSIBLE ELECTRICAL FIRE. USE ONLY THE PROPER "CIGARETTE LIGHTER" ADAPTER DESIGNED FOR YOUR SPECIFIC TELEVISION.

Also located on this panel is a television 75 ohm RF antennae hookup.

LP GAS

General

The Liquid Petroleum Gas System in your unit furnishes fuel for heating and cooling. It is comprised of propane or a blend of propane and butane, depending upon the locale. LP gas provides an efficient and inexpensive source of energy.

The gas is stored in a pressure tank located on or under the chassis of your unit. Under pressure, the LP gas turns to vapor; it is the vapor that burns.

Each tank has an automatic eighty percent Stop-Fill Valve that allows space in the tank for vapor expansion. The high pressure of the vapor in the tank is reduced in two stages as it makes its way to your appliance. The tank pressure will vary with temperature and altitude, but it may be in the range of 100 to 250 pounds per square inch (psi) or more. It is reduced by a pressure regulator to about 12 psi in the first stage and then to about 6.25 ounces in the second stage. The 6.25 ounces psi can also be expressed as 11 inches of water column.

The LP gas system is designed and built to rigid standards and tested before leaving the factory. Your dealer also tests the system prior to customer delivery.

NOTE: YOUR DEALER IS RESPONSIBLE FOR A THOROUGH LP GAS SYSTEM CHECK PRIOR TO DELIVERY. DO NOT ACCEPT THE UNIT UNTIL THIS

CHECK HAS BEEN COMPLETED.

Except for simple maintenance and occasionally tightening a connection, you should take your unit to an authorized dealer for LP gas problems. The LP gas tank should always be filled by an authorized LP supplier.

NOTE: YOUR UNIT'S MANUFACTURER IS NOT RESPONSIBLE FOR PERSONAL INJURY OR PROPERTY DAMAGE RESULTING FROM IMPROPERLY MAINTAINED LP GAS APPLIANCES AND SYSTEMS.

CAUTIONS: READ LP GAS PRECAUTIONS IN THE FRONT OF THIS MANUAL. BECOME FAMILIAR WITH THEM AND MAKE SURE YOUR ENTIRE FAMILY IS COMPLETELY AWARE OF THE SAFETY ASPECTS OF LIVING AROUND LP GAS.

Climate Differences

The appliances in your vehicle will not function if the LP gas does not vaporize. Butane will not vaporize below 32 degrees (F), but Propane will continue to vaporize down to -44 degrees (F).

Propane has become the main type of LP gas used in RVs in recent years. The LP gas dealer will have the correct type or blend for his locale. If you plan on traveling from a warm climate to a cold climate, check with your local gas dealer to see if the blend he supplies is appropriate for the part of the country you plan on visiting.

Operation

To operate any LP gas appliance, the LP gas tank's service valve must be OPEN. When first used, or after a refill, there may be some air in the gas lines that will escape when the range burner or similar gas valve is opened. The air may extinguish the match or igniter the first time or two you attempt to light up.

Also remember that when you close the tank's service valve, some gas will remain in the lines. To completely bleed the lines of gas, close the tank valve and light the range burner. When the flame burns out, turn off the appliance (FIG. 10).

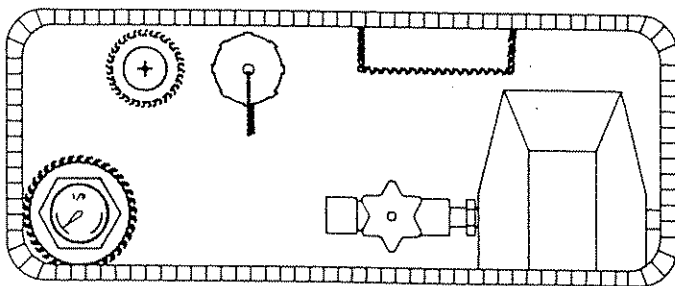

(FIG. 10) LP GAS TANK

Filling the LP Tank

Make sure that all burners and pilot lights are turned OFF prior to having a gas supplier refill your LP tank.

Drive your unit to the LP supplier for filling. Never remove the tank from the unit. The supplier will connect his fill nozzle to your unit's LP tank FILL VALVE.

When the tank is being filled, the service valve must be CLOSED. The 20 percent LIQUID LEVEL GAUGE must be OPEN.

The 80 percent STOP FILL VALVE may close the valve before liquid appears at the 20 percent liquid level gauge, but if liquid does appear, stop filling immediately. The tank is filled to its LP capacity.

When liquid gas is no longer visible, CLOSE the liquid level gauge.

Do not use a wrench to tighten the service valve or the 20 percent gauge. They are both designed to be closed leak-tight by hand. If you cannot hand-tighten the valve, the valve may need repair or replacement. Consult your gas dealer.

YOUR LP TANK MUST BE KEPT FREE OF RUST AT ALL TIMES. IF RUST DOES DEVELOP, THE TANK SHOULD BE CLEANED COMPLETELY FREE OF THE RUST, PRIMED, AND PAINTED WHITE (OR SOME OTHER HIGHLY REFLECTIVE COLOR) WHICH WILL HELP TO REDUCE EXPANSION OF THE LP GAS BECAUSE OF HEAT.

Gas Line Check

Check the gas line connection and all other connections regularly. To check, turn OFF all burners and pilot lights. Open all doors and windows. OPEN the LP gas tank service valve and use soapy water or an approved leak detector fluid to test all line connections. Do not use products that contain AMMONIA or CHLORINE. The appearance of bubbles in the soapy solution indicates a leak. Tighten the connections with two open-end wrenches until the bubbles stop. If this does not take care of the leak, contact your gas dealer. DO NOT OVER-TIGHTEN. (FIG. 11)

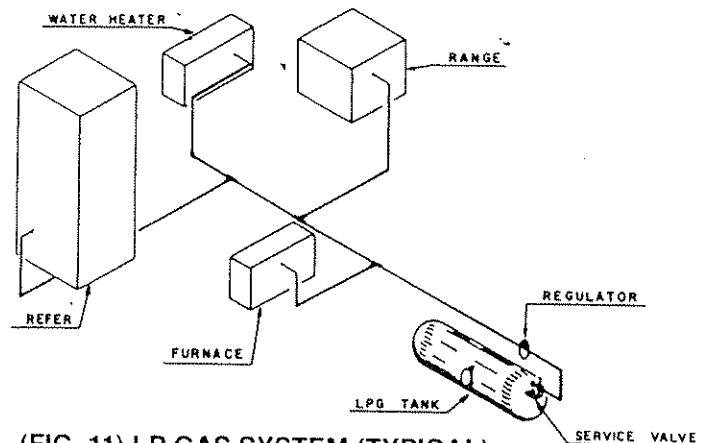

(FIG. 11) LP GAS SYSTEM (TYPICAL)

Regulator Pressure

Have the gas regulator checked at the beginning of each season and whenever a problem occurs. Proper line pressure is 11 inches of water column. Your RV dealer or gas supplier can perform this needed check.

Gas Tank and Regulator Freeze-Up

LP gas regulator freeze-up can be prevented if owners are aware of its causes. Freeze-up may be caused by one of these things: moisture in the tank, an overfilled tank of a greater vapor withdrawal demand than the tank can deliver at a particular temperature.

Freeze-up occurs more frequently in cold weather since liquid gas does not vaporize as quickly. This, along with a higher demand, can cause frosting of the tank and regulator. Be sure to have your LP gas supplier add ANHYDROUS METHANOL before filling the tank in cold weather.

Moisture may enter the tank in the LP gas through condensation if air is allowed to enter the tank through an open valve. This can be avoided by using moisture-free gas and keeping all tank valves CLOSED during storage. If moisture is present, have the tank purged by an authorized dealer and have him add the proper amount of ANHYDROUS METHANOL for your tank.

An overfilled tank can allow liquid gas, rather than the needed vapor, to flow through the regulator. This can result in erratic regulator delivery pressure, improper appliance operation and possible frosting of the regulator and gas line. This can be avoided by following the procedures outlined in "Filling the Gas Tank." Always contact your local gas supplier for current procedures.

Hose Replacement

The sun's ultraviolet rays and Earth's ozone damage the rubber hoses that are part of the LP gas system. The hoses on your unit should be checked regularly for signs of deterioration and should be replaced every two to three years...the average useful life of hoses. Be sure to replace the hoses with approved and properly rated products.

Regulator Vent Maintenance

Since the LP gas regulator is equipped with a vent that allows the system to "breathe," you must check it on a routine basis to see that it does not become clogged. If dirt, sealant or corrosion clogs the vent, clean it with a toothbrush. At least once a year have your LP serviceman check the regulator for adjustment and operation.

PLUMBING

Fresh Water

Fresh water for your RV is provided by filling the FRESH WATER TANK or by hooking directly to a city water connection. These sources supply water to the

kitchen sink, tub/shower, lavatory, toilet and water heater. (FIG. 12)

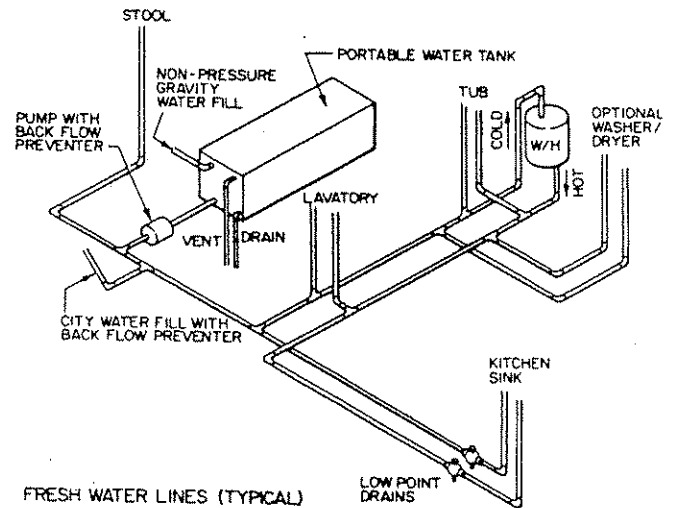

(FIG. 12) FRESH WATER LINES (TYPICAL)

CITY WATER

Open the CITY WATER INLET DOOR and connect a hose to a city pressurized water faucet and to the vehicle's CITY WATER INLET. You cannot fill the water tank through the city water inlet. The water tank and pump are by-passed when the city water hook-up is used. A hose manufactured for this purpose may be used to fill water tanks and connect to city water.

CAUTION: A PRESSURE REGULATOR SHOULD BE USED IN AREAS WHERE CITY WATER PRESSURE EXCEEDS 60 PSI. EXCESSIVE WATER PRESSURE CAN DAMAGE LINES AND CONNECTIONS. SEE YOUR DEALER FOR MORE INFORMATION.

WATER TANK

UNLOCK the GRAVITY WATER FILL HATCH and use a hose or vessel to fill the water tank. Water will flow out the fill opening when the tank is full.

USE ONLY FRESH, POTABLE WATER IN THE STORAGE TANK. TO INSURE THAT THE TANK IS CLEAN, DRAIN AFTER EACH TRIP. SANITIZE THE TANK WHEN NEW, WHENEVER CONTAMINATION IS SUSPECTED, OR WHENEVER IT HAS NOT BEEN USED FOR A LONG PERIOD OF TIME.

Sanitizing the Water Tank

To drain, OPEN the WATER TANK VALVE. When the tank is empty, CLOSE the valve. Mix three (3) gallons of water with three-quarters cup of LIQUID HOUSEHOLD BLEACH. Pour this solution into the tank through the GRAVITY FILL. Wait three hours, drain and flush with fresh drinking water.

Water Pump

The RV water pump is a 12-volt DC appliance that is activated by a SWITCH in the kitchen area or on the monitor panel. The switch may be left ON while camping. This is called a demand system. (FIG. 13)

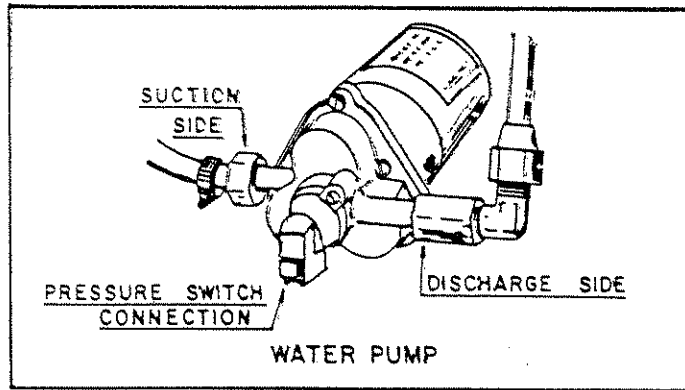

(FIG. 13) WATER PUMP

Turn the faucet ON when you want water. The pump will run only as long as needed. If the pump fails when the switch is ON, check the fuse located in the ELECTRICAL CONVERTER. If the pump continues to operate whether the faucet is open or closed, check the water tank to see if it is empty and check to see if there is a leak in the system.

DO NOT RUN THE WATER PUMP WITHOUT WATER IN THE SYSTEM. ALWAYS KEEP THE PUMP SWITCH OFF WHEN THE SYSTEM IS EMPTY OR WHEN CONNECTED TO CITY WATER. RUNNING THE PUMP DRY CAN DAMAGE IT AND VOID THE WARRANTY.

Winterizing the Water Pump

With the water drained from the potable water tank, disconnect the water pump outlet hose and then turn the pump on to allow the remaining water to be pumped out (less than one cup).

If you desire, you can blow out the water lines with compressed air by opening all valves and placing the air nozzle into the system where the outlet hose was disconnected. Replace the pump hose.

Trouble Shooting Water Pump Problems

If you encounter problems getting water from your system, check the tightness of the WATER PUMP HEAD SCREWS. This can cause any one of the following problems ...

1. **WATER PUMP MOTOR DOES NOT OPERATE.** Check the battery charge to see if it is sufficient. Check to see if all wires are connected. Is the water pump switch "on"? Is the fuse blown? Is the water pump head frozen? If it is, place a light bulb next to it and allow it to thaw out.

2. **WATER PUMP RUNS, BUT NO WATER AT ALL COMES OUT.** Check the water level of the water tank. Check for kinks in the water hose. Is there air leaking into the system? Is the inlet line clogged? Detach the outlet hose and see if the water pump is pumping ... if it is, then the problem is down the line. If it isn't, check further up the line.
3. **WATER PUMP RUNS, BUT WATER ONLY SPUTTERS OUT.** This indicates that air is getting into the line somewhere. Check hose clamps on the input side of the pump since this condition would not result from an air leak on the outlet side. After checking clamps, restart, letting trapped air escape from the lines and hot water tank. Then, see if the problem clears up.
4. **WATER PUMP OPERATES IN RAPID ON/OFF CYCLES.** This is normal if the flow of water is restricted to less than the flow capacity of the water pump; a partially opened faucet will cause this.
5. **ABNORMAL CYCLING.** If the water pump cycles on/off when there is no demand on the system (the faucets are closed), there is a problem. There is probably a water leak somewhere and you need to check the water system to see where this water is going. Check for leaking faucets and especially the toilet valve. Correct all water leaks no matter how small they may seem. Check the city exterior water supply input connection to see if there is a leak.

If you can't find a leak, shut off the pump and remove the outlet hose connection, leaving the hose connected to the pump. Connect a completely leak-proof plug to the open end of the disconnected outlet hose. A bolt the size of the hose's interior diameter can be pushed into the hose and then sealed tightly with a hose clamp. DO NOT USE ANY SEALER OR PIPE DOPE SINCE THIS COULD CLOG THE SYSTEM'S LINES AFTER RECONNECTION.

Once the seal is completed, turn on the pump. The pump should run a minute or two and then shut off. If it does shut off, it indicates that the problem (leak?) is not in the pump. If, on the other hand, the pump keeps on cycling on/off with the plug in place, there might be a problem with the pump. If the switch is stuck, try tapping the head of the pump with a screwdriver handle. There are several other internal and external reasons for a pump to malfunction. If you can't locate the problem, check with your RV serviceman or the nearest water pump service center.

Leaks

Traveling over bumps and rough roads can cause pipe fittings to loosen. Check fittings regularly for signs of leakage.

Drainage and Sewer

Your RV has a Drainage/Sewer system that operates much the same way as the one in your home. How extensive the system is depends on your unit model and

the options you obtained. It includes a drain line from the kitchen sink, shower and lavatory to a GRAY WATER HOLDING TANK. There is also a marine toilet that empties into a separate WASTE HOLDING TANK. (FIG. 14)

NOTE: SOME MODELS MAY HAVE THE LAVATORY WATER DRAIN DIRECTLY TO THE WASTE HOLDING TANK.

The drainage system also includes vents that carry odors caused by drain water and waste out of the RV, while also equalizing air pressure. Drain cleanouts are provided to clean lines between fixtures and holding tanks.

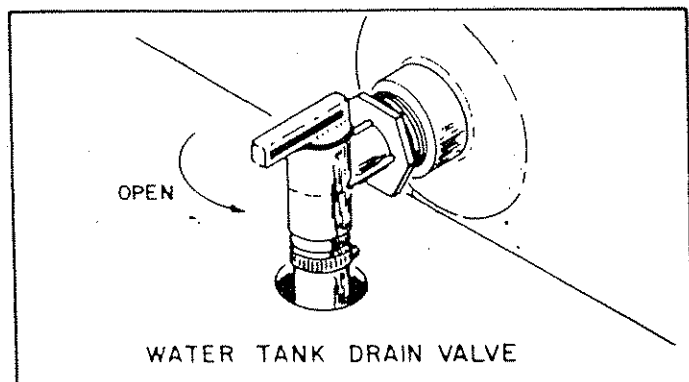

(FIG. 14) WATER TANK DRAIN VALVE

Holding Tanks

Your unit has a GRAY WATER HOLDING TANK and a WASTE HOLDING TANK. The tanks should be emptied frequently, or as indicated on the optional MONITOR PANEL. The tanks should always be emptied at a special DUMPING STATION. Most campgrounds and highway rest stops and many gasoline stations are equipped with proper dumping facilities.

Emptying Holding Tanks

To empty the holding tanks, be certain that your RV is level since this process depends upon gravity. Remove the SEWAGE DRAIN HOSE from its storage compartment. Remove the cap from the TERMINATION OUTLET and connect the drain hose.

If you leave the hose connected to the termination valve when you are camped, do not open the valve until you wish to empty the holding tank. If the valve is left open, only liquid waste may drain out, causing solids to collect and harden in the bottom of the waste holding tank.

NOTE: DRAIN THE TOILET (WASTE) HOLDING TANK FIRST.

To drain either holding tank, pull out the TERMINATION VALVE (FIG. 15) by pulling out the dump valve SLIDE HANDLE. Close the valve after the tank has drained. Flush or pour about two gallons of water through the toilet when emptying the waste tank and drain again. This flushes the tank and helps clean the drain hose. Repeat as necessary.

Follow the same procedure for a GRAY WATER HOLDING TANK. A repeat flush is not necessary. When the tank is empty, push dump valve handle IN until it seats. Remove the hose, wash and replace it in its compartment. Replace termination outlet cap.

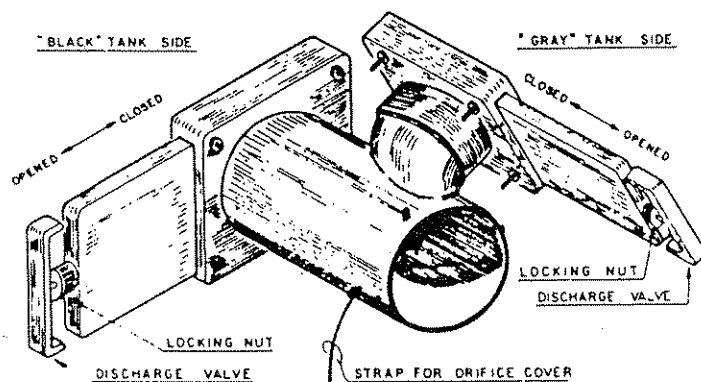

(FIG. 15) TERMINATION VALVES

Drain Piping

To drain sink water in units not equipped with a gray water holding tank, remove the protective cap located on the unit's side. Attach a garden hose to the outlet. Some campgrounds and rest stops will have septic service for the disposal of sink water. If not, collect the water in a bucket and dispose of as required by park rules. (FIG. 16)

WARNING:

HOLDING TANKS ARE ENCLOSED SEWER SYSTEMS AND MUST BE DRAINED INTO AN APPROVED DUMP STATION OR GROUND DISPOSAL AREA. HOLDING TANKS MUST BE DRAINED AND CLEANED REGULARLY TO PREVENT THE BUILD UP OF HARMFUL OR TOXIC MATERIALS OR FUMES.

- DO CLEAN THE HOLDING TANK WITH AN APPROVED CLEANER.
- DO ADD A SPECIAL CHEMICAL ADDITIVE TO SANITIZE AND IMPROVE TANK ACTION.
- DO GUARD THE TANK AGAINST FREEZE UP.
- DO KEEP DUMP VALVES CLOSED TO ALLOW THE TANKS TO GET AS FULL AS POSSIBLE TO FACILITATE DRAINAGE.
- DO KEEP THE DUMP VALVE CLOSED AND THE DRAIN CAP IN PLACE TO ALLOW THE USE OF THE SYSTEM WHILE TRAVELING.
- DO USE ANY SOFT SINGLE PLY TISSUE.

DO NOT PUT FACIAL TISSUES, PAPER, AUTOMOTIVE TYPE ANTI-FREEZE, SANITARY NAPKINS OR HOUSEHOLD TOILET CLEANERS IN YOUR HOLDING TANK.

DO NOT PUT FOREIGN OBJECTS IN THE SYSTEM WHICH COULD CLOG OR DAMAGE IT IN ANY WAY.

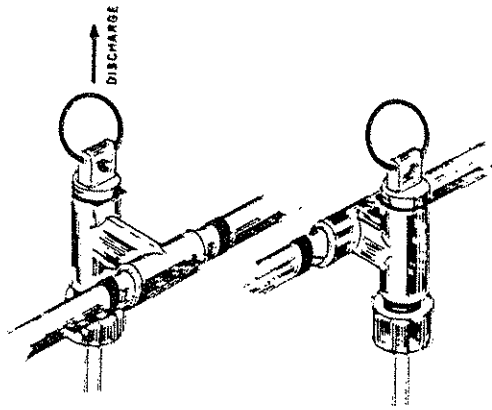

(FIG. 16) LOW POINT DRAINS

To avoid contaminating your water system, use different color hoses for fresh and drain water. Hoses designed specifically to be used on RVs for drinking water are available.

Use clear water to clean exterior pipe surfaces. Do not use harsh drain cleaner or solvents in drains. Drain cleanouts have been installed to facilitate cleaning and unclogging. (FIG. 17)

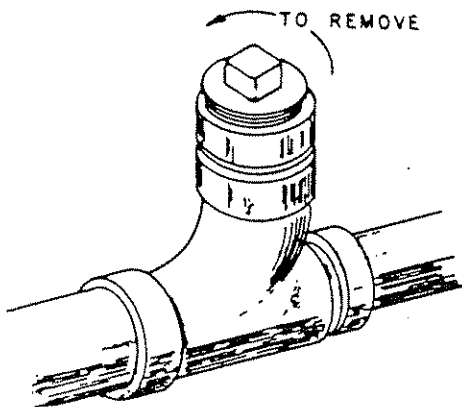

(FIG. 17) DRAIN CLEANOUT

Water Heater

The hot water heater is operated on LP gas and is much like the one in your home. Full operating instructions are to be found in the manufacturer's owner's manual and some details are in this manual's APPLIANCE SECTION.

Water System Winterizing

NOTE: READ THIS BEFORE WINTERIZING YOUR WATER SYSTEM.

If your RV is going to be stored unheated in temperature that COULD GO BELOW FREEZING, the fresh water and waste systems must be winterized.

Follow this procedure:

1. Drain the fresh water hold tank.
2. Drain pipes by turning the water pump ON and opening a cold water faucet. Wait for the water flow to

- stop. Turn pump OFF. Leave faucets OPEN.
3. Turn ON all faucets and OPEN the HOT & COLD WATER PIPE DRAIN VALVES. Leave these valves in the OPEN position. These valves are located under the galley sink and permit the water to drain onto the ground below the RV.
4. OPEN the WATER HEATER drain valve located at the bottom of the heater. Let the water drain out. OPEN the heater SAFETY VALVE.
5. Flush the toilet.
6. After each faucet has been opened, drained and closed, CLOSE the WATER LINE DRAIN VALVES.
7. Drain the WASTE WATER HOLDING TANK.
8. Double check that ALL WATER has been drained.
9. Secure all protective caps including the water tank filler, city water inlet and waste drain outlet.

CAUTION: DRAINING THE WATER SYSTEM ALONE MAY NOT BE ENOUGH TO PROVIDE COMPLETE COLD WEATHER PROTECTION FOR AN RV UNIT THAT WILL BE STORED IN AN UNHEATED ENVIRONMENT WHERE TEMPERATURES DROP BELOW FREEZING. CONSULT YOUR DEALER FOR MORE INFORMATION ON THE BEST METHOD OF WINTERIZING YOUR VEHICLE.

WARNING: DO NOT USE AUTOMOTIVE ANTI-FREEZE OR WINDSHIELD WASHER FLUID ANTI-FREEZE IN THE MOTOR HOME WATER SYSTEM. THESE CAN BE HARMFUL IF SWALLOWED. YOUR DEALER CAN PROVIDE YOU SPECIAL ANTI-FREEZES THAT ARE SAFE AND APPROVED FOR RV WATER SYSTEMS. ALWAYS FOLLOW MANUFACTURER'S INSTRUCTION FOR THESE ADDITIVES.

Appliances

Your RV is similar to your home when it comes to convenience. What has made this possible are the appliances included in the kitchen and other areas.

Refer to your respective manufacturer's owner's manuals for the appliances that are provided with your vehicle. These manuals give detailed information on the operation, care and warranties on these appliances.

WARNING:

THE HOT WATER HEATER AND THE FURNACE USE LP GAS AS FUEL, AND IN THE COURSE OF NORMAL OPERATION HAVE PARTS/SURFACES THAT BECOME VERY HOT AND ALSO EMIT COMBUSTION GASES. BE CAREFUL TO ALWAYS FOLLOW MANUFACTURER'S RECOMMENDATIONS ON VENTILATION AND DO NOT TOUCH THE AIR EXHAUST PORTS OR ALLOW ANY MATERIAL TO COVER THEM OR EVEN COME IN CONTACT WITH EITHER THE INTAKE OR EXHAUST OF THESE APPLIANCES.

WHENEVER YOU OR SOMEONE IN YOUR VEHICLE SMELLS LP GAS, TAKE PRECAUTIONS AS OUTLINED EARLIER IN THIS MANUAL.

Water Heater

NEVER LIGHT THE HOT WATER HEATER WITHOUT FIRST FILLING IT WITH WATER.

The water heater on your RV is very similar to the one in your home. It operates on LP gas and, if the water gets too hot, is equipped with an AUTOMATIC SHUT OFF VALVE that will cut off the gas supply to the heater.

The water heater is accessed by a panel on the outside of the vehicle (FIG. 18). Turn on the hot water faucet at the galley sink to see if the tank is full. Operating instructions can be found in the manufacturer's owner's manual.

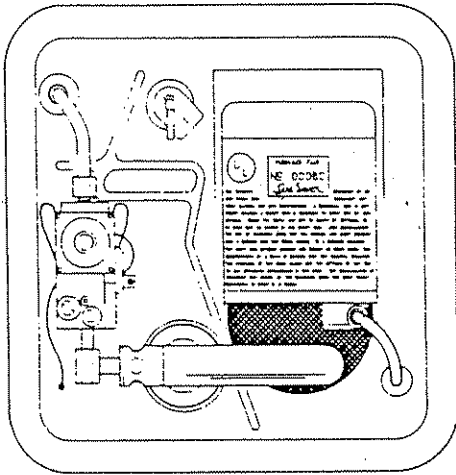

(FIG. 18) WATER HEATER

Range

Also operated with LP gas are the range burners and the oven. The basic operation is the same as the units in your home except that extra care must be taken to provide adequate ventilation in your RV. Unlike your home, the RV has limited air space, thus, a limited amount of oxygen available for combustion.

WARNING: DO NOT USE OPEN FLAMES, SUCH AS THE RANGE BURNERS, TO WARM THE LIVING AREA OF THE RV. THE FLAMES CONSUME THE OXYGEN IN THE VEHICLE AND COULD RESULT IN ASPHYXIATION.

Always provide adequate ventilation when using the range and oven. It is always best to use the range exhaust hood and open a window slightly.

Your owner's packet contains owner's manuals for the oven and range. Read these over carefully to become familiar with the safe operation of these appliances.

Microwave

Like many homes, your RV might have a microwave oven on board to make life more convenient. Read over the oven's owner's manual to find all information on its operation and cleaning.

Refrigerator

Unlike your home refrigerator, the unit on your RV can be operated with two different sources of power: LP gas and 12-volt/120-volt electricity. Read over your owner's manual provided in your owner's packet before putting the refrigerator into operation.

The refrigerator will not operate correctly if the vehicle is not level while parked. The refrigerator coolant will not circulate properly if the unit is not level.

For best results, locate the refrigerator vent door in the shade and place only pre-cooled items inside. If the outside temperature is high and warm items are placed into the refrigerator, it will take much longer for the food to cool.

Dishwasher

Some RV units are equipped with an automatic dishwasher. Remember that this unit is part of the plumbing of your vehicle and care must be taken to insure that the dishwasher does not harm or interfere with the rest of the system. Please consult your owner's manual that details the operation and maintenance of the dishwasher.

Washer/Dryer

Optional on some units are washer/dryer combinations. The unit is part of the RV plumbing system and, therefore, you must take into consideration its use in relation to the other parts of the system. Consult your owner's packet for the manuals that cover these units.

Furnishings

Your unit is equipped with PEDESTAL TABLES that are assembled by inserting the leg into the base on the floor and then placing the table onto the leg by means of its support bracket. (FIG. 19)

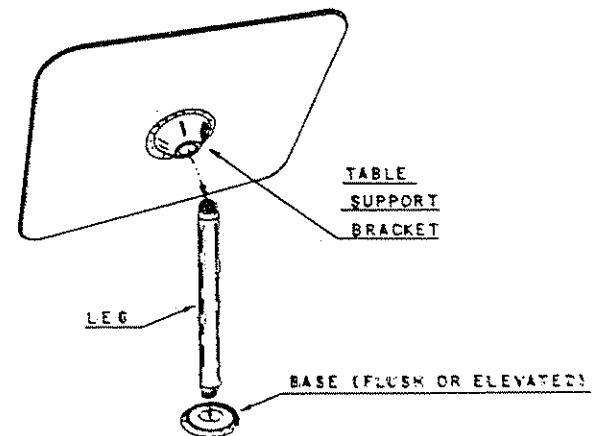

(FIG. 19) PEDESTAL TABLE

The DINETTE TABLE is supported by wall brackets and a single leg attached to the underside of the table top. The TWO-WAY DINETTE TABLE converts into a bed by removing the table from its wall brackets (FIG. 20) and then laying the table top between the tow dinette seats. Slide the dinette seat cushions over the top of the table and lay the cushion backs flat on the outsides of the seat cushions.

Chairs

The CAPTAIN'S CHAIRS can be moved backward and forward by pulling outward on the lever located under the LEFT side of the seat, holding the lever and sliding the seat into the desired position. Release the lever when the desired position is obtained. (FIG. 21)

To swivel the seat, push back on the lever under the RIGHT side of the seat and turn the seat to the desired position. Release the lever. The chair can be reclined by pulling UP on the lever on the right side of the seat. To return the seat to the upright position, pull on the lever a second time.

BARREL CHAIRS can be adjusted by using the levers on the base of the seat, but they will not recline. (FIG. 22)

Cabinets

Cabinets can be cleaned with a mild, non-abrasive cleaner and a damp cloth.

Walls

Walls can be cleaned with a damp cloth and an occasional use of a very mild non-abrasive cleaner.

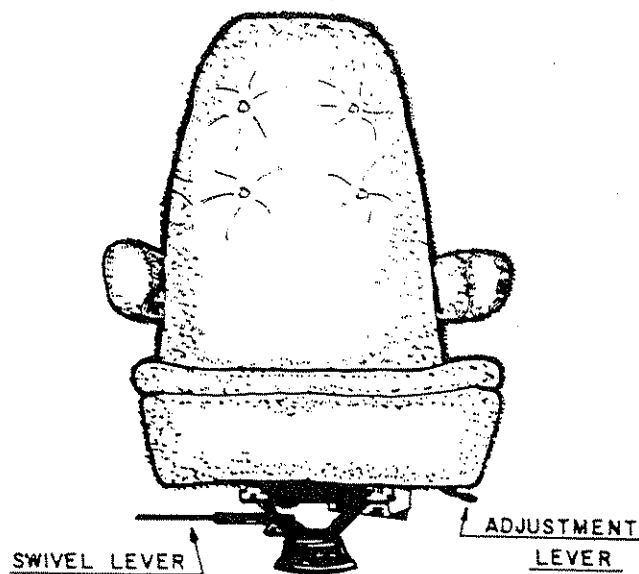

(FIG. 21) CAPTAIN'S CHAIR

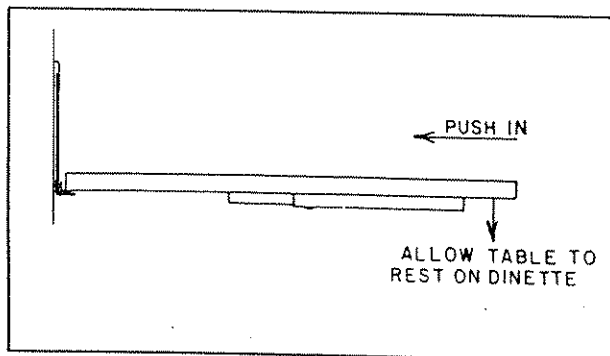
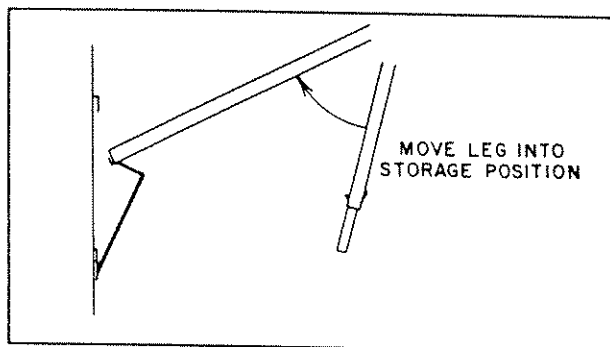
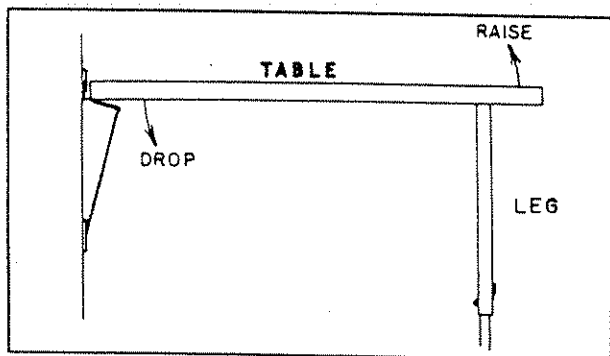

(FIG. 20) DINETTE TABLE AS A BED

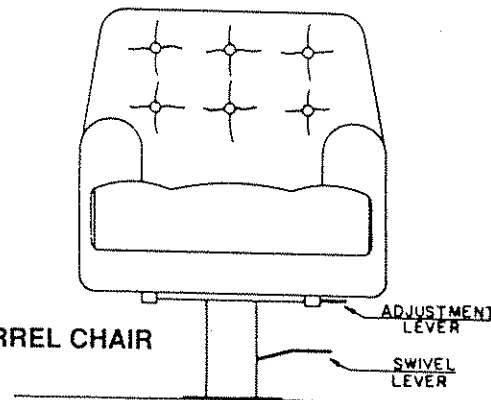

(FIG. 22) BARREL CHAIR

Carpets

Regular vacuuming will keep the carpets free of dirt, but an occasional cleaning will be in order. It is best not to use water-based cleaners or concentrated household cleaners that are diluted with water.

Climate Control

Attention to climate control in your RV is very important since it is much more critical than in your larger home. The RV, because of its modern construction, is sealed more tightly than the average home. The interior environment is also much more compact than your home, therefore it is easy to get a high ratio of people to square footage. This leads to air that is more quickly saturated with moisture.

The air, under various climactic conditions, can contain only a certain amount of moisture before that moisture

starts to condense on interior surfaces. With some attention paid to air circulation, water condensation can be controlled.

The RV was primarily engineered to serve as a recreational vehicle with its owners occupying it for short periods of time. If you plan on using the vehicle for more extended periods, pay close attention to this section of your owner's manual.

Furnace

Your RV is equipped with a forced-air furnace similar to the type found in most homes with the exception that it is fueled by LP gas. Each unit is equipped with a wall-mounted thermostat that controls the temperature. An operating manual for the furnace was included in your owner's packet. For more detailed information on how your furnace operates, consult this publication.

WARNING: DO NOT SUPPLEMENT THE FURNACE WITH ANY PORTABLE FUEL-BURNING APPLIANCE FOR HEATING THE INTERIOR OF THE MOTOR HOME. THESE APPLIANCES ARE NOT SAFE; ASPHYXIATION/ CARBON MONOXIDE POISONING IS POSSIBLE IN ANY SMALL, WELL-SEALED SPACE.

Air Conditioner

Many motor homes are equipped with an air conditioning system that works with electrical power from either a shore line or a portable generator. Consult your owner's packet for details on the air conditioner's use and maintenance.

As with the refrigerator, the air conditioner will work more efficiently if the RV is parked in a shaded area and the window shades are closed. Less frequent opening and closing of the RV's doors will help keep the cool air inside the vehicle.

Air conditioners do remove a portion of the moisture in the air and can help control condensation.

Effects of Long Term Occupancy

Your motor home was designed primarily for recreational use and short term occupancy. If you expect to live in your motor home for extended periods of time, be prepared to deal with condensation and the humid conditions that may be encountered. The normal activities of even a small number of occupants in the relatively small volume of a modern recreational vehicle with its tight construction, will lead to rapid saturation of the air inside the vehicle and the appearance of visible moisture, especially during cold weather.

Estimates indicate that a family of four can vaporize up to three gallons of water daily through its breathing,

cooking, bathing and washing. Unless this vapor is carried outside by ventilation, or removed from the air by a dehumidifier, it will condense on the inside of the windows and walls as moisture. In cold weather it will appear as frost or ice. It may also condense in the walls or ceiling and appear as stains on the paneling. This will increase the heating load on the furnace somewhat, but it will greatly reduce condensation. You should increase ventilation when large numbers of people are present.

NOTE: EVEN WHEN IT IS RAINING OR SNOWING, OUTSIDE AIR IS MUCH DRYER THAN INTERIOR AIR AND WILL EFFECTIVELY REDUCE CONDENSATION. BE SURE TO RUN THE POWER VENT.

CAUTION: DO NOT USE COOKING APPLIANCES FOR COMFORT HEATING. IN ADDITION TO THE TOXIC FUMES AND OXYGEN DEPLETION, OPEN FLAMES ADD MOISTURE TO THE AIR INCREASING CONDENSATION.

Ventilate closets and cabinets during cold weather, leave closet and cabinet doors open to warm and ventilate the interiors of storage compartments which are built against exterior walls. The air flow will warm the exterior wall surface, reducing condensation.

Controlling Condensation

Interior condensation can be reduced or eliminated (during cold weather) with the following steps:

1. Ventilate with outside air.
2. Partially open one or more roof vents and windows to provide controlled circulation of outside air to the inside of the motor home.

Dehumidifier

The use of a dehumidifier may prove to be the most effective way to keep excessive moisture out of the air inside during long term usage. Used in conjunction with the above ventilation techniques, a dehumidifier can help reduce the amount of outside air needed to properly ventilate the RV and prevent condensation.

Do not heat the RV with the range or oven because, in addition to possibly giving off toxic fumes, the fires actually add to the moisture problem.

Vehicle Maintenance

Cleaning the exterior bodywork of your motor home follows the guidelines for any quality vehicle. Washing on a regular schedule, at least once each month, will go a long way in keeping your vehicle looking like new.

WASH the RV with a quality, mild soap. There are special automotive cleaners on the market and available at full-service auto parts centers. **DO NOT USE STRONG ALKALINE CLEANERS OR CLEANERS WITH ABRASIVES.**

WAXING the exterior will further protect the vehicle's outside surfaces. Wax the RV once a year at least, twice would be better still. **USE A WAX FORMULATED FOR FIBERGLASS ...** most of the exterior of your vehicle is made of fiberglass. Follow the instructions found on the product label.

Also on the market are products specific for cleaning and polishing chrome and rubber. There are products that will take off road tar, check to be sure that the product is compatible with fiberglass. The product may also remove your wax job, so re wax the area that has been cleaned of road tar. Most of these products are produced from petrochemicals and are flammable so use as directed in a well ventilated area.

CAUTION: DO NOT USE ABRASIVES, HARSH CLEANERS OR SOLVENTS TO CLEAN YOUR MOTOR HOME. THESE COULD DULL THE FINISH AND/OR DAMAGE THE PAINTED SURFACES AND GRAPHICS.

Roof and body seams must be cleaned and inspected on a routine basis, at least annually, and renewed with an approved sealant when necessary. Your dealer can assist you with this and supply the proper sealants.

Corrosion Protection

Your Gulf Stream recreational vehicle has been designed to withstand normal environmental conditions. But, the sand and salt used on the highways and the salt spray in the air near the oceans can cause the metal components on your recreational vehicle to corrode.

To protect your recreational vehicle from this corrosion, it must be thoroughly cleaned as soon as possible after exposure to these elements. Washing the undercarriage with a high-pressure washer will remove the majority of the salt. But, this will not replace the paint that is literally sand-blasted off the undercarriage by the road salt and sand. Sand-blasted and corroded frame components must be refinished. This can be done with readily available rust preventative paint and undercoating. This is necessary to properly maintain your recreational vehicle.

We have also found generators to be affected by salt spray. Since the generator requires air for operation and cooling, the generator compartment cannot be completely sealed from the elements. Therefore, whenever the recreational vehicle is exposed to salt spray, the generator should also be cleaned.

After-market undercoating processes are also beneficial in rust prevention. But, to remain effective, these treatments must be inspected and renewed annually as most undercoating agents can dry and peel with age.

Therefore, regularly scheduled inspections and maintenance is necessary to protect your recreational vehicle and its various exposed components and fixtures from the elements and keep it corrosion-free.

Reporting Safety Defects

If you believe that your vehicle has a defect which could cause a crash or could cause injury or death, you should immediately inform the National Highway Traffic Safety Administration (NHTSA) in addition to notifying GULF STREAM COACH, Inc.

If NHTSA receives similar complaints, it may open an investigation, and if it finds that a safety defect exists in a group of vehicles, it may order a recall and remedy campaign. However, NHTSA cannot become involved in individual problems between you, your dealer, or GULF STREAM COACH, Inc.

To contact NHTSA, you may either call the Auto Safety Hotline toll-free at 1-800-424-9393 or (366-0123 in the Washington, D.C. area) or write to: NHTSA, U.S. Department of Transportation, Washington, D.C. 20590. You can also obtain other information about motor vehicle safety from the Hotline.

READY REFERENCE

Names, Locations and Phone Numbers of Your Motor Home Dealers and Local Service Contacts.

It could save you time and effort if you list the names, locations, and phone numbers below, of those who you can quickly contact for warranty or maintenance service on the various components of your motor home. You can readily get emergency information directly from the retail dealer or from the warranties and operational instructions that accompany the various appliances and equipment listed on the next page.

GULF STREAM warrants only the proper installation of appliances. The appliances themselves are warranted by their respective manufacturers. In the event that any of the appliances in your motor home require service or replacement under the terms of the manufacturer's warranty, you should contact the manufacturer directly. Appliance service centers are listed in the manufacturer's literature.

Your MOTOR HOME DEALER

Name _____

Address _____

Phone _____

Motor Home Serial No. _____

Closest CHASSIS MANUFACTURER DEALER: _____

Serial No. _____ Model No. _____ Brand _____

Local REFRIGERATOR Service: _____

Serial No. _____ Model No. _____ Brand _____

Local RANGE Service: _____

Serial No. _____ Model No. _____ Brand _____

Local FURNACE Service: _____

Serial No. _____ Model No. _____ Brand _____

Local HOT WATER HEATER Service: _____

Serial No. _____ Model No. _____ Brand _____

Local TOILET Service: _____

Serial No. _____ Model No. _____ Brand _____

Local GENERATOR Service: _____

Serial No. _____ Model No. _____ Brand _____

Local AIR CONDITIONING Service: _____

Serial No. _____ Model No. _____ Brand _____

Other EMERGENCY NUMBERS: _____

Note: Appliance and related equipment in recreational vehicles might not be serviceable by your local plumbing and appliance dealers. Please contact your local RV serv-

ice and warranty station or your local dealer for service on these items.

NOTES

INDEX

A

Air Bag Warning	8
Air Conditioning	23
Anti-Freeze	20
Appliances	20
Auxiliary Power Generator	15

B

Battery	14
Beds	21
Brakes	10, 13

C

Cabinets	22
Carbon Monoxide Dangers	23
Carpets	22
Chairs	22
City Water Hook-up	17
Climate Control	22
Climate Differences (LP gas)	16
Condensation Problems	23
Cooling Fan Noise	11
Cruise Control	10

D

Dashboard Instruments	11
Definitions of Weights (Federal)	6
Dehumidifier	23
Determining Weight Distribution	7
Dishwasher	21
Drain Piping	19
Drainage and Sewer	18
Driving Characteristics	10
Driver Controls	10
Dryer	21
Dumping Procedure (waste)	19

E

Electrical System	13
Emergency Exits	13
Emergency/Parking Brake	13
Emptying Holding Tank	19
Exterior Maintenance	23

F

Federal Weight Definitions	6
Fire Extinguisher	13
Fire Safety	4
Furnace	23
Furnishings	21
Fuse Boxes	15

G

Gas Line Check (LP gas)	16
Gasoline Tank Safety	5
Ground Fault Interrupter	14
Gulf Streamers	26

H

Holding Tanks (fresh water)	19
(waste water)	19
Hose Replacement (LP gas)	17
Humidity Problems	23

I

Index	27
Interior Humidity Build-Up	23
Introduction	1
Instruments (dashboard)	11

J

Jump Starting	12
---------------------	----

L

Labels (manufacturer's)	6
Leaks (water)	18
Load Capacity	5
Loading Tips	6
Long Term Occupancy	23
LP Gas	3, 5, 15
(filling tank)	16
(hose replacement)	17
(line check)	16
(operation)	16
(regulator)	17
(safety)	3, 5, 15
(vent maintenance)	17

M

Manufacturer's Labels	6
Method of Weighing Your Vehicle	7
Microwave Oven	21
Monitor Panel	15

INDEX (Continued)

O

On-board Power Generator.....	15
Optional Equipment.....	12
Oven.....	21
Overloading Precautions.....	8

P

Plumbing System.....	17
Pre-Trip Checklist – Camp.....	9
Pre-Trip Checklist – Home.....	9
Power Converter.....	13
Power Generator.....	15

R

Range.....	21
Ready Reference.....	24
Refrigerator.....	21
Regulator (LP Gas).....	17
Rubber Hose Replacement (LP Gas).....	17

S

Safety (belts).....	4
(LP gas).....	3, 5, 15
(gasoline tank).....	5
(general).....	4
(reporting defects).....	24
Sanitizing (water tank).....	17
Seat Adjustment.....	22
Seat Belts.....	4
Sewer and Drainage.....	18
Smoke Detector.....	5, 13
Starting.....	12
Steering Wheel Adjustment.....	10

T

Table of Contents.....	1
Tables.....	21
Television Electrical Connection.....	15
Tilt Steering Wheel.....	10
Towing (emergency).....	8
(vehicle).....	8
Trouble Shooting the Water Pump.....	18
Two Speed Cooling Fan Noise.....	11

U

Unused Dashboard Switches.....	12
Useful Weights.....	7

V

Vehicle Carrying Capacity.....	5
Vehicle Maintenance.....	23
Vehicle Systems.....	13
Vent Maintenance (LP gas).....	17

W

Walls.....	22
Warning/Hazard Flashers.....	13
Warranty.....	3
Washer/Dryer.....	21
Waste Water Holding Tanks.....	19
Water Heater.....	20
Water Pump.....	18
(troubleshooting).....	18
(winterizing).....	18
Water System (winterizing).....	20
Water Tank (sanitizing).....	17
Weight Capacity.....	5
Weight Distribution in Loading.....	7
Weight Planning Guide.....	8



Gulf Streamers International RV Club

Enjoy your RV lifestyle to the fullest - join the Gulf Streamers International RV Club today.

Now that you own a Gulf Stream recreational vehicle, why not join our international Gulf Stream travel club, the Gulf Streamers! To join, fill out this application and mail to the address shown. The general purpose of the Gulf Streamers is to promote fellowship among owners of Gulf Stream recreational vehicles. Other benefits include the MAIN STREAM newsletter, Streamwear (discounted apparel), the "10% Program" (discounted camping) and optional Gulf Streamers Emergency Road Service and RV Insurance opportunities (best in the industry!).

GULF STREAMERS APPLICATION

Name _____
(Last) (First) (Middle Initial)

Spouse's Name _____

Address _____

City _____ State/Prov. _____ ZIP _____

Telephone _____

Model _____ Year _____

Serial Number _____
Serial Numbers Begin with 51, 52, 53, 58, 59

Check or Money Order (in U.S. Funds) Only. Payable To: Gulf Streamers Int'l RV Club

Return this form and your dues to: Gulf Streamers Int'l RV Club
P.O. Box 1005
Nappanee, IN 46550-0905
(219) 773-7761

New Membership Dues Are:

<input type="checkbox"/> One Year	\$25.00
<input type="checkbox"/> Two Years	\$33.00
<input type="checkbox"/> Three Years	\$40.00

Membership dues are non-refundable. Membership in the Gulf Streamers is limited to owners of Gulf Stream recreational vehicles. Any Gulf Stream employee, dealer or their employees are welcome to join as Associate Members.



NOTES

